

# TOGE TSM High Performance

Allrounder Concrete Screw - for heavy loads



### Large variety

Seven different head shapes and up to three different embedment depths for variable load absorption: always perfectly matched to your individual requirements.

### Easy and fast installation

The optimized thread enables a fast and easy installation process.

### Particularly near the edge

Small edge distances and spacing allow very closed-edge and closely spaced installation.

### Adjustable & Demountable

If required, the TOGE TSM High Performance can be adjusted up to twice during assembly. After assembly, it can be disassembled again at any time.

### High load level

The special thread geometry ensures extreme hold and high loads in concrete – whether tensile or shear loads.

### Combinable system

In combination with our composite mortar, the TSM HP has an even higher load level – and can be loaded immediately. Tested impermeability, even to critical substances, enables use even under WHG requirements (only for TSM LT A4).

## Approval

### Approval

European technical assessment ETA-15/0514, single fastening.

European technical assessment ETA-16/0123, multiple fastening.

European technical assessment ETA-21/0425, TSM LT A4.

European technical assessment ETA-23/0099, single fastening in masonry.

General design approval Z-21.8-2115 for temporary fastening.

General design approval Z-21.1-2074 adhesive concrete screw.

### Base Material

Approved for concrete strength classes from C20/25 to C50/60.

Cracked and non-cracked concrete.





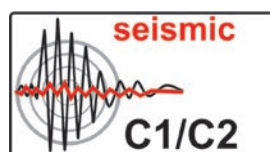

Prestressed hollow core slabs (size 6).

Approved for masonry.

Suitable for natural stone with dense structure.

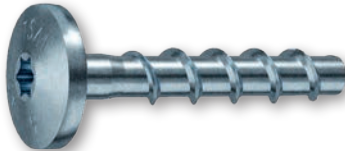

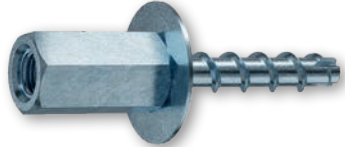
# Headshapes & Materials

		Steel, zinc plated	Steel, zinc flake-coated	Stainless steel A4
	Hexagon head and pressed-on washer	✓	✓	✓
	Countersunk head with multipoint drive	✓		✓
	Panhead with multipoint drive	✓		✓
	Large panhead with multipoint drive	✓		
	Hexagonal drive and metric external thread M8 and M10	✓		
	Metric female thread M8/M10	✓		✓
	Metric external thread	✓		✓

# Application Examples



Fastening piping



Fastening of racks in high-bay warehouses



Fastening cable ducts



Fastening railings



Fastening ventilation ducts



# Product Overview

## Steel - zinc plated

Version with hexagon head and pressed-on washer



Size	Washer-Ø
5	12,5 mm
6	15,0 mm
8	16,0 mm
10	20,0 mm
12	23,5 mm
14	28,5 mm

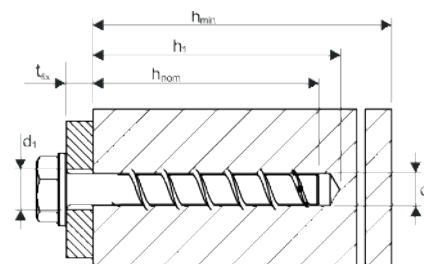

Item nr.	Designation	Depth of drill hole $h_{01} / h_{02} / h_{03}$	Embedment depth of anchor $h_{nom1} / h_{nom2} / h_{nom3}$	Max. thickness of fixture $t_{fix1} / t_{fix2} / t_{fix3}$	Packing Unit
300 005 040	TSM 5x40 SW10	40mm / - / -	35mm / - / -	5mm / - / -	100
300 005 050	TSM 5x50 SW10	40mm / - / -	35mm / - / -	15mm / - / -	100
300 005 060	TSM 5x60 SW10	40mm / - / -	35mm / - / -	25mm / - / -	100
300 006 040	TSM 6x40 SW13	40mm / - / -	35mm / - / -	5mm / - / -	100
300 006 050	TSM 6x50 SW13	40mm / 45mm / -	35mm / 40mm / -	15mm / 10mm / -	100
300 006 060	TSM 6x60 SW13	40mm / 45mm / 60mm	35mm / 40mm / 55mm	25mm / 20mm / 5mm	100
300 006 080	TSM 6x80 SW13	40mm / 45mm / 60mm	35mm / 40mm / 55mm	45mm / 40mm / 25mm	100
300 006 100	TSM 6x100 SW13	40mm / 45mm / 60mm	35mm / 40mm / 55mm	65mm / 60mm / 45mm	100
300 008 050	TSM 8x50 SW13	55mm / - / -	45mm / - / -	5mm / - / -	50
300 008 060	TSM 8x60 SW13	55mm / 65mm / -	45mm / 55mm / -	15mm / 5mm / -	50
300 008 070	TSM 8x70 SW13	55mm / 65mm / 75mm	45mm / 55mm / 65mm	25mm / 15mm / 5mm	50
300 008 080	TSM 8x80 SW13	55mm / 65mm / 75mm	45mm / 55mm / 65mm	35mm / 25mm / 15mm	50
300 008 090	TSM 8x90 SW13	55mm / 65mm / 75mm	45mm / 55mm / 65mm	45mm / 35mm / 25mm	50
300 008 100	TSM 8x100 SW13	55mm / 65mm / 75mm	45mm / 55mm / 65mm	55mm / 45mm / 35mm	50
300 008 120	TSM 8x120 SW13	55mm / 65mm / 75mm	45mm / 55mm / 65mm	75mm / 65mm / 55mm	50
300 008 140	TSM 8x140 SW13	55mm / 65mm / 75mm	45mm / 55mm / 65mm	95mm / 85mm / 75mm	50
300 010 060	TSM 10x60 SW 15	65mm / - / -	55mm / - / -	5mm / - / -	50
300 010 070	TSM 10x70 SW15	65mm / - / -	55mm / - / -	15mm / - / -	50
300 010 080	TSM 10x80 SW15	65mm / 85mm / -	55mm / 75mm / -	25mm / 5mm / -	50
300 010 090	TSM 10x90 SW15	65mm / 85mm / 95mm	55mm / 75mm / 85mm	35mm / 15mm / 5mm	50
300 010 100	TSM 10x100 SW15	65mm / 85mm / 95mm	55mm / 75mm / 85mm	45mm / 25mm / 15mm	50
300 010 120	TSM 10x120 SW15	65mm / 85mm / 95mm	55mm / 75mm / 85mm	65mm / 45mm / 35mm	50
300 010 140	TSM 10x140 SW15	65mm / 85mm / 95mm	55mm / 75mm / 85mm	85mm / 65mm / 55mm	50
300 010 150	TSM 10x150 SW15	65mm / 85mm / 95mm	55mm / 75mm / 85mm	95mm / 75mm / 65mm	50
300 010 160	TSM 10x160 SW15	65mm / 85mm / 95mm	55mm / 75mm / 85mm	105mm / 85mm / 75mm	50
300 010 180	TSM 10x180 SW15	65mm / 85mm / 95mm	55mm / 75mm / 85mm	125mm / 105mm / 95mm	25
300 010 200	TSM 10x200 SW15	65mm / 85mm / 95mm	55mm / 75mm / 85mm	145mm / 125mm / 115mm	25
300 010 240	TSM 10x240 SW15	65mm / 85mm / 95mm	55mm / 75mm / 85mm	185mm / 165mm / 155mm	25
300 010 280	TSM 10x280 SW15	65mm / 85mm / 95mm	55mm / 75mm / 85mm	225mm / 205mm / 195mm	25
300 010 320	TSM 10x320 SW15	65mm / 85mm / 95mm	55mm / 75mm / 85mm	265mm / 245mm / 235mm	25

Type list - continued on p. 4



## Steel - zinc plated

Version with hexagon head and pressed-on washer



Size	Washer-Ø
5	12,5 mm
6	15,0 mm
8	16,0 mm
10	20,0 mm
12	23,5 mm
14	28,5 mm

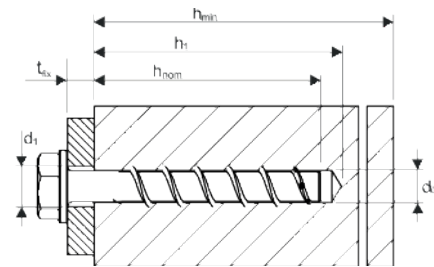

Type list - continued from p. 3

Item nr.	Designation	Depth of drill hole $h_{01} / h_{02} / h_{03}$	Embedment depth of anchor $h_{nom1} / h_{nom2} / h_{nom3}$	Max. thickness of fixture $t_{fix1} / t_{fix2} / t_{fix3}$	Packing Unit
300 010 360	TSM 10x360 SW15	65mm / 85mm / 95mm	55mm / 75mm / 85mm	305mm / 285mm / 275mm	25
300 010 400	TSM 10x400 SW15	65mm / 85mm / 95mm	55mm / 75mm / 85mm	345mm / 325mm / 315mm	25
300 012 080	TSM 12x80 SW17	75mm / - / -	65mm / - / -	15mm / - / -	25
300 012 110	TSM 12x110 SW17	75mm / 95mm / 110mm	65mm / 85mm / 100mm	45mm / 25mm / 10mm	25
300 012 130	TSM 12x130 SW17	75mm / 95mm / 110mm	65mm / 85mm / 100mm	65mm / 45mm / 30mm	25
300 012 150	TSM 12x150 SW17	75mm / 95mm / 110mm	65mm / 85mm / 100mm	85mm / 65mm / 50mm	25
300 014 080	TSM 14x80 SW21	85mm / - / -	75mm / - / -	5mm / - / -	25
300 014 110	TSM 14x110 SW21	85mm / 110mm / -	75mm / 100mm / -	35mm / 10mm / -	25
300 014 130	TSM 14x130 SW21	85mm / 110mm / 125mm	75mm / 100mm / 115mm	55mm / 30mm / 15mm	25
300 014 150	TSM 14x150 SW21	85mm / 110mm / 125mm	75mm / 100mm / 115mm	75mm / 50mm / 35mm	25

## Steel - zinc plated

Version with countersunk head  
with multipoint drive

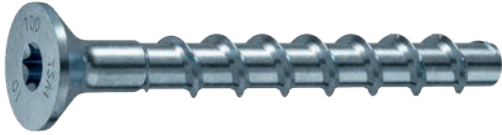

Size	Head-Ø
5	12,0 mm
6	13,0 mm
8	19,5 mm
10	21,5 mm

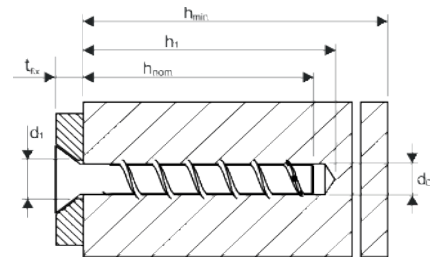

Item nr.	Designation	Depth of drill hole $h_{01} / h_{02} / h_{03}$	Embedment depth of anchor $h_{nom1} / h_{nom2} / h_{nom3}$	Max. thickness of fixture $t_{fix1} / t_{fix2} / t_{fix3}$	Packing Unit
311 005 040	TSM 5x40 C VZ25	40mm / - / -	35mm / - / -	5mm / - / -	100
311 005 050	TSM 5x50 C VZ25	40mm / - / -	35mm / - / -	15mm / - / -	100
311 005 060	TSM 5x60 C VZ25	40mm / - / -	35mm / - / -	25mm / - / -	100
311 006 040	TSM 6x40 C VZ30	40mm / - / -	35mm / - / -	5mm / - / -	100
311 006 050	TSM 6x50 C VZ30	40mm / 45mm / -	35mm / 40mm / -	15mm / 10mm / -	100
311 006 060	TSM 6x60 C VZ30	40mm / 45mm / 60mm	35mm / 40mm / 55mm	25mm / 20mm / 5mm	100
311 006 080	TSM 6x80 C VZ30	40mm / 45mm / 60mm	35mm / 40mm / 55mm	45mm / 40mm / 25mm	100
311 006 100	TSM 6x100 C VZ30	40mm / 45mm / 60mm	35mm / 40mm / 55mm	65mm / 60mm / 45mm	100
311 006 120	TSM 6x120 C VZ30	40mm / 45mm / 60mm	35mm / 40mm / 55mm	85mm / 80mm / 65mm	100
311 006 140	TSM 6x140 C VZ30	40mm / 45mm / 60mm	35mm / 40mm / 55mm	105mm / 100mm / 85mm	100
311 008 080	TSM 8x80 C VZ40	55mm / 65mm / 75mm	45mm / 55mm / 65mm	35mm / 25mm / 15mm	50
311 008 100	TSM 8x100 C VZ40	55mm / 65mm / 75mm	45mm / 55mm / 65mm	55mm / 45mm / 35mm	50
311 008 120	TSM 8x120 C VZ40	55mm / 65mm / 75mm	45mm / 55mm / 65mm	75mm / 65mm / 55mm	50
311 010 090	TSM 10x90 C VZ50	65mm / 85mm / 95mm	55mm / 75mm / 85mm	35mm / 15mm / 5mm	50
311 010 100	TSM 10x100 C VZ50	65mm / 85mm / 95mm	55mm / 75mm / 85mm	45mm / 25mm / 15mm	50
311 010 120	TSM 10x120 C VZ50	65mm / 85mm / 95mm	55mm / 75mm / 85mm	65mm / 45mm / 35mm	50



## Steel - zinc plated

Version with panhead and multipoint drive

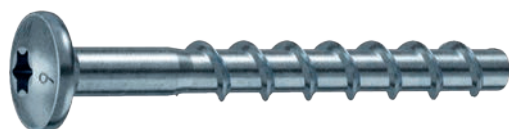

Size	Head-Ø
5	14,0 mm
6	14,5 mm

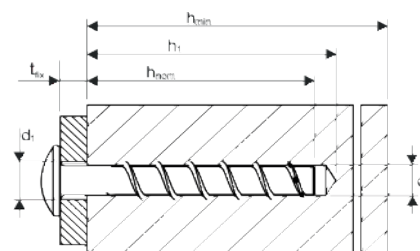

Item nr.	Designation	Depth of drill hole $h_{01} / h_{02} / h_{03}$	Embedment depth of anchor $h_{nom1} / h_{nom2} / h_{nom3}$	Max. thickness of fixture $t_{fix1} / t_{fix2} / t_{fix3}$	Packing Unit
322 005 040	TSM 5x40 P VZ30	40mm / - / -	35mm / - / -	5mm / - / -	100
322 005 050	TSM 5x50 P VZ30	40mm / - / -	35mm / - / -	15mm / - / -	100
322 005 060	TSM 5x60 P VZ30	40mm / - / -	35mm / - / -	25mm / - / -	100
322 006 040	TSM 6x40 P VZ30	40mm / - / -	35mm / - / -	5mm / - / -	100
322 006 050	TSM 6x50 P VZ30	40mm / 45mm / -	35mm / 40mm / -	15mm / 10mm / -	100
322 006 060	TSM 6x60 P VZ30	40mm / 45mm / 60mm	35mm / 40mm / 55mm	25mm / 20mm / 5mm	100
322 006 080	TSM 6x80 P VZ30	40mm / 45mm / 60mm	35mm / 40mm / 55mm	45mm / 40mm / 25mm	100
322 006 100	TSM 6x100 P VZ30	40mm / 45mm / 60mm	35mm / 40mm / 55mm	65mm / 60mm / 45mm	100

## Steel - zinc plated

Version with large panhead and multipoint drive

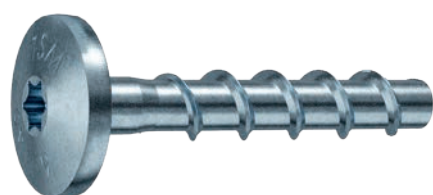

Size	Head-Ø
6	18,0 mm

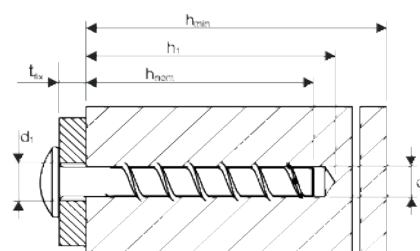

Item nr.	Designation	Depth of drill hole $h_{01} / h_{02} / h_{03}$	Embedment depth of anchor $h_{nom1} / h_{nom2} / h_{nom3}$	Max. thickness of fixture $t_{fix1} / t_{fix2} / t_{fix3}$	Packing Unit
333 006 040	TSM 6x40 LP VZ30	40mm / - / -	35mm / - / -	5mm / - / -	100
333 006 060	TSM 6x60 LP VZ30	40mm / 45mm / 60mm	35mm / 40mm / 55mm	25mm / 20mm / 5mm	100

## Steel - zinc plated

Version with hexagonal drive and metric external thread M8

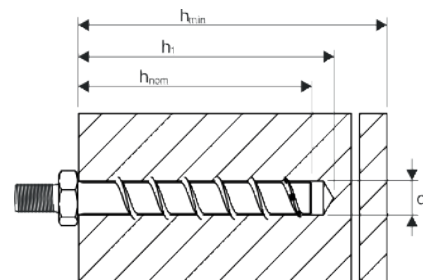

Item nr.	Designation	Depth of drill hole $h_{01} / h_{02} / h_{03}$	Embedment depth of anchor $h_{nom1} / h_{nom2} / h_{nom3}$	Max. thickness of fixture $t_{fix1} / t_{fix2} / t_{fix3}$	Packing Unit
355 006 035	TSM 6x35 K M8-16 SW10	40mm / - / -	35mm / - / -	- / - / -	100
355 006 055	TSM 6x55 M8-16 SW10	40mm / 45mm / 60mm	35mm / 40mm / 55mm	20mm / 15mm / -	100
355 006 075	TSM 6x75 M8-16 SW10	40mm / 45mm / 60mm	35mm / 40mm / 55mm	40mm / 35mm / 20mm	100
355 006 095	TSM 6x95 M8-16 SW10	40mm / 45mm / 60mm	35mm / 40mm / 55mm	60mm / 55mm / 40mm	100
355 006 135	TSM 6x135 M8-16 SW10	40mm / 45mm / 60mm	35mm / 40mm / 55mm	100mm / 95mm / 80mm	100
355 006 155	TSM 6x155 M8-16 SW10	40mm / 45mm / 60mm	35mm / 40mm / 55mm	120mm / 115mm / 100mm	100
355 006 175	TSM 6x175 M8-16 SW10	40mm / 45mm / 60mm	35mm / 40mm / 55mm	140mm / 135mm / 120mm	100
355 006 195	TSM 6x195 M8-16 SW10	40mm / 45mm / 60mm	35mm / 40mm / 55mm	160mm / 155mm / 140mm	100

## Steel - zinc plated

Version with hexagonal drive and metric external thread M10



Size 6  
Washer-Ø 19,0 mm

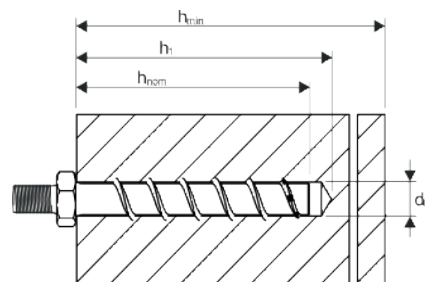

Item nr.	Designation	Depth of drill hole $h_{01} / h_{02} / h_{03}$	Embedment depth of anchor $h_{nom1} / h_{nom2} / h_{nom3}$	Max. thickness of fixture $t_{fix1} / t_{fix2} / t_{fix3}$	Packing Unit
355 206 040	TSM 6x40 M10-20 SW13	40mm / 45mm / -	35mm / 40mm / -	5mm / - / -	100

## Steel - zinc plated

Version with metric female thread  
M8/M10

Size 6  
Washer-Ø 25,0 mm

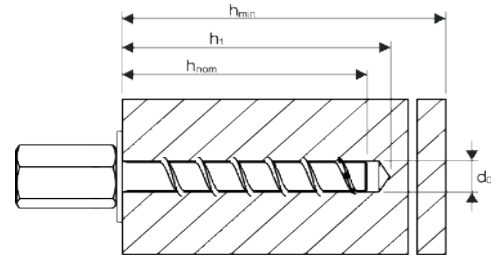
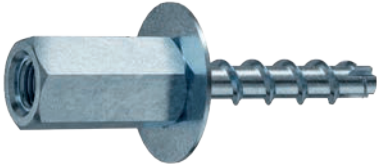

Item nr.	Designation	Depth of drill hole $h_{01} / h_{02} / h_{03}$	Embedment depth of anchor $h_{nom1} / h_{nom2} / h_{nom3}$	Max. thickness of fixture $t_{fix1} / t_{fix2} / t_{fix3}$	Packing Unit
344 006 035	TSM 6x35 K IM 8/10	40mm / - / -	35mm / - / -	- / - / -	50
344 006 055	TSM 6x55 IM 8/10	40mm / 45mm / 65mm	35mm / 40mm / 55mm	20mm / 15mm / -	50

## Steel - zinc plated

Version with metric external thread  
M10

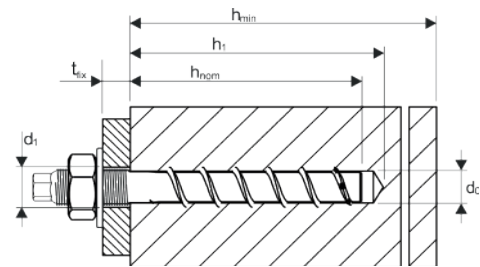

Item nr.	Designation	Depth of drill hole $h_{01} / h_{02} / h_{03}$	Embedment depth of anchor $h_{nom1} / h_{nom2} / h_{nom3}$	Max. thickness of fixture $t_{fix1} / t_{fix2} / t_{fix3}$	Packing Unit
366 008 105	TSM 8x105 M10x30 SW7	55mm / 65mm / 75mm	45mm / 55mm / 65mm	39mm / 29mm / 19mm	50
366 010 120	TSM 10x120 M12x20 SW9	65mm / 85mm / 95mm	55mm / 75mm / 85mm	40mm / 20mm / 10mm	50



## Steel - zinc-flake coated

Version with hexagon head and pressed-on washer



Size	Washer-Ø
5	12,5 mm
6	15,0 mm
8	16,0 mm
10	20,0 mm
12	23,5 mm
14	28,5 mm

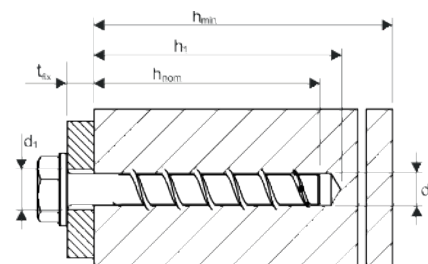

Item nr.	Designation	Depth of drill hole $h_{01} / h_{02} / h_{03}$	Embedment depth of anchor $h_{nom1} / h_{nom2} / h_{nom3}$	Max. thickness of fixture $t_{fix1} / t_{fix2} / t_{fix3}$	Packing Unit
400 005 040	TSM 5x40 SW10 ZFC	40mm / - / -	35mm / - / -	5mm / - / -	100
400 005 050	TSM 5x50 SW10 ZFC	40mm / - / -	35mm / - / -	15mm / - / -	100
400 005 060	TSM 5x60 SW10 ZFC	40mm / - / -	35mm / - / -	25mm / - / -	100
400 006 040	TSM 6x40 SW13 ZFC	40mm / - / -	35mm / - / -	5mm / - / -	100
400 006 050	TSM 6x50 SW13 ZFC	40mm / 45mm / -	35mm / 40mm / -	15mm / 10mm / -	100
400 006 060	TSM 6x60 SW13 ZFC	40mm / 45mm / 60mm	35mm / 40mm / 55mm	25mm / 20mm / 5mm	100
400 006 080	TSM 6x80 SW13 ZFC	40mm / 45mm / 60mm	35mm / 40mm / 55mm	45mm / 40mm / 25mm	100
400 006 100	TSM 6x100 SW13 ZFC	40mm / 45mm / 60mm	35mm / 40mm / 55mm	65mm / 60mm / 45mm	100
400 008 050	TSM 8x50 SW13 ZFC	55mm / - / -	45mm / - / -	5mm / - / -	50
400 008 060	TSM 8x60 SW13 ZFC	55mm / 65mm / -	45mm / 55mm / -	15mm / 5mm / -	50
400 008 070	TSM 8x70 SW13 ZFC	55mm / 65mm / 75mm	45mm / 55mm / 65mm	25mm / 15mm / 5mm	50
400 008 080	TSM 8x80 SW13 ZFC	55mm / 65mm / 75mm	45mm / 55mm / 65mm	35mm / 25mm / 15mm	50
400 008 090	TSM 8x90 SW13 ZFC	55mm / 65mm / 75mm	45mm / 55mm / 65mm	45mm / 35mm / 25mm	50
400 008 100	TSM 8x100 SW13 ZFC	55mm / 65mm / 75mm	45mm / 55mm / 65mm	55mm / 45mm / 35mm	50
400 008 120	TSM 8x120 SW13 ZFC	55mm / 65mm / 75mm	45mm / 55mm / 65mm	75mm / 65mm / 55mm	50
400 008 140	TSM 8x140 SW13 ZFC	55mm / 65mm / 75mm	45mm / 55mm / 65mm	95mm / 85mm / 75mm	50
400 010 060	TSM 10x60 SW 15 ZFC	65mm / - / -	55mm / - / -	5mm / - / -	50
400 010 070	TSM 10x70 SW15 ZFC	65mm / - / -	55mm / - / -	15mm / - / -	50
400 010 080	TSM 10x80 SW15 ZFC	65mm / 85mm / -	55mm / 75mm / -	25mm / 5mm / -	50
400 010 090	TSM 10x90 SW15 ZFC	65mm / 85mm / 95mm	55mm / 75mm / 85mm	35mm / 15mm / 5mm	50
400 010 100	TSM 10x100 SW15 ZFC	65mm / 85mm / 95mm	55mm / 75mm / 85mm	45mm / 25mm / 15mm	50
400 010 120	TSM 10x120 SW15 ZFC	65mm / 85mm / 95mm	55mm / 75mm / 85mm	65mm / 45mm / 35mm	50
400 010 140	TSM 10x140 SW15 ZFC	65mm / 85mm / 95mm	55mm / 75mm / 85mm	85mm / 65mm / 55mm	50
400 010 150	TSM 10x150 SW15 ZFC	65mm / 85mm / 95mm	55mm / 75mm / 85mm	95mm / 75mm / 65mm	50
400 010 160	TSM 10x160 SW15 ZFC	65mm / 85mm / 95mm	55mm / 75mm / 85mm	105mm / 85mm / 75mm	50
400 010 180	TSM 10x180 SW15 ZFC	65mm / 85mm / 95mm	55mm / 75mm / 85mm	125mm / 105mm / 95mm	25
400 010 200	TSM 10x200 SW15 ZFC	65mm / 85mm / 95mm	55mm / 75mm / 85mm	145mm / 125mm / 115mm	25
400 010 240	TSM 10x240 SW15 ZFC	65mm / 85mm / 95mm	55mm / 75mm / 85mm	185mm / 165mm / 155mm	25
400 010 280	TSM 10x280 SW15 ZFC	65mm / 85mm / 95mm	55mm / 75mm / 85mm	225mm / 205mm / 195mm	25
400 010 320	TSM 10x320 SW15 ZFC	65mm / 85mm / 95mm	55mm / 75mm / 85mm	265mm / 245mm / 235mm	25

Type list - continued on p. 10



## Steel - zinc-flake coated

Version with hexagon head and pressed-on washer



Size	Washer-Ø
5	12,5 mm
6	15,0 mm
8	16,0 mm
10	20,0 mm
12	23,5 mm
14	28,5 mm

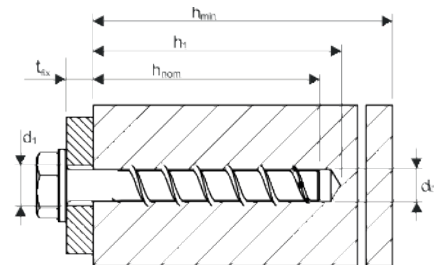

Type list - continued from p. 9

Item nr.	Designation	Depth of drill hole $h_{01} / h_{02} / h_{03}$	Embedment depth of anchor $h_{nom1} / h_{nom2} / h_{nom3}$	Max. thickness of fixture $t_{fix1} / t_{fix2} / t_{fix3}$	Packing Unit
400 010 360	TSM 10x360 SW15 ZFC	65mm / 85mm / 95mm	55mm / 75mm / 85mm	305mm / 285mm / 275mm	25
400 010 400	TSM 10x400 SW15 ZFC	65mm / 85mm / 95mm	55mm / 75mm / 85mm	345mm / 325mm / 315mm	25
400 012 080	TSM 12x80 SW17 ZFC	75mm / - / -	65mm / - / -	15mm / - / -	25
400 012 110	TSM 12x110 SW17 ZFC	75mm / 95mm / 110mm	65mm / 85mm / 100mm	45mm / 25mm / 10mm	25
400 012 130	TSM 12x130 SW17 ZFC	75mm / 95mm / 110mm	65mm / 85mm / 100mm	65mm / 45mm / 30mm	25
400 012 150	TSM 12x150 SW17 ZFC	75mm / 95mm / 110mm	65mm / 85mm / 100mm	85mm / 65mm / 50mm	25
400 014 080	TSM 14x80 SW21 ZFC	85mm / - / -	75mm / - / -	5mm / - / -	25
400 014 110	TSM 14x110 SW21 ZFC	85mm / 110mm / -	75mm / 100mm / -	35mm / 10mm / -	25
400 014 130	TSM 14x130 SW21 ZFC	85mm / 110mm / 125mm	75mm / 100mm / 115mm	55mm / 30mm / 15mm	25
400 014 150	TSM 14x150 SW21 ZFC	85mm / 110mm / 125mm	75mm / 100mm / 115mm	75mm / 50mm / 35mm	25

## Stainless steel - LT A4

Version with hexagon head and pressed-on washer



Size	Washer-Ø
6	17,0 mm
8	16,0 mm
10	20,0 mm

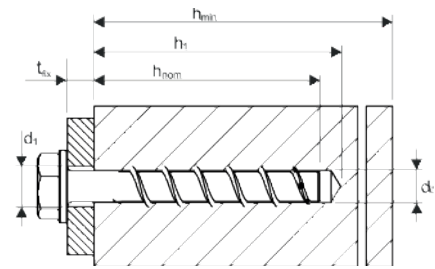

Item nr.	Designation	Depth of drill hole $h_{01} / h_{02} / h_{03}$	Embedment depth of anchor $h_{nom1} / h_{nom2} / h_{nom3}$	Max. thickness of fixture $t_{fix1} / t_{fix2} / t_{fix3}$	Packing Unit
700 006 050	TSM 6x50 SW13 LT A4	40mm / 50mm / -	35mm / 45mm / -	15mm / 5mm / -	100
700 006 060	TSM 6x60 SW13 LT A4	40mm / 50mm / 60mm	35mm / 45mm / 55mm	25mm / 15mm / 5mm	100
700 008 070	TSM 8x70 SW13 LT A4	55mm / 65mm / 75mm	45mm / 55mm / 65mm	25mm / 15mm / 5mm	50
700 008 080	TSM 8x80 SW13 LT A4	55mm / 65mm / 75mm	45mm / 55mm / 65mm	35mm / 25mm / 15mm	50
700 010 090	TSM 10x90 SW15 LT A4	65mm / 85mm / 95mm	55mm / 75mm / 85mm	35mm / 15mm / 5mm	50
700 010 100	TSM 10x100 SW15 LT A4	65mm / 85mm / 95mm	55mm / 75mm / 85mm	45mm / 25mm / 15mm	50
700 010 120	TSM 10x120 SW15 LT A4	65mm / 85mm / 95mm	55mm / 75mm / 85mm	65mm / 45mm / 35mm	50

## Stainless Steel - LT A4

Version with countersunk head with multipoint drive



Size	Head-Ø
6	13,0 mm
8	19,5 mm
10	21,5 mm

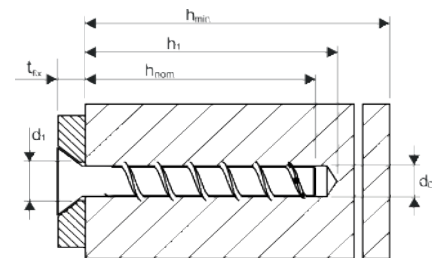

Item nr.	Designation	Depth of drill hole $h_{01} / h_{02} / h_{03}$	Embedment depth of anchor $h_{nom1} / h_{nom2} / h_{nom3}$	Max. thickness of fixture $t_{fix1} / t_{fix2} / t_{fix3}$	Packing Unit
711 006 050	TSM 6x50 C VZ30 LT A4	40mm / 50mm / -	35mm / 45mm / -	15mm / 5mm / -	100
711 006 065	TSM 6x65 C VZ30 LT A4	40mm / 50mm / 60mm	35mm / 45mm / 55mm	30mm / 20mm / 10mm	100
711 006 085	TSM 6x85 C VZ30 LT A4	40mm / 50mm / 60mm	35mm / 45mm / 55mm	50mm / 40mm / 30mm	100
711 006 105	TSM 6x105 C VZ30 LT A4	40mm / 50mm / 60mm	35mm / 45mm / 55mm	70mm / 60mm / 50mm	100
711 008 080	TSM 8x80 C VZ40 LT A4	55mm / 65mm / 75mm	45mm / 55mm / 65mm	35mm / 25mm / 15mm	50
711 008 100	TSM 8x100 C VZ40 LT A4	55mm / 65mm / 75mm	45mm / 55mm / 65mm	55mm / 45mm / 35mm	50
711 008 120	TSM 8x120 C VZ40 LT A4	55mm / 65mm / 75mm	45mm / 55mm / 65mm	75mm / 65mm / 55mm	50
711 010 090	TSM 10x90 C VZ50 LT A4	65mm / 85mm / 95mm	55mm / 75mm / 85mm	35mm / 15mm / 5mm	50
711 010 100	TSM 10x100 C VZ50 LT A4	65mm / 85mm / 95mm	55mm / 75mm / 85mm	45mm / 25mm / 15mm	50
711 010 120	TSM 10x120 C VZ50 LT A4	65mm / 85mm / 95mm	55mm / 75mm / 85mm	65mm / 45mm / 35mm	50

## Stainless Steel - LT A4

Version with panhead and multipoint drive

Size 6  
Head-Ø 15,0 mm

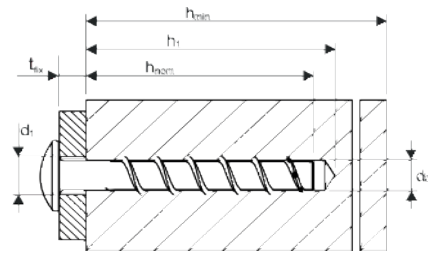

Item nr.	Designation	Depth of drill hole $h_{01} / h_{02} / h_{03}$	Embedment depth of anchor $h_{nom1} / h_{nom2} / h_{nom3}$	Max. thickness of fixture $t_{fix1} / t_{fix2} / t_{fix3}$	Packing Unit
722 006 050	TSM 6x50 P VZ30 LT A4	40mm / 50mm / -	35mm / 45mm / -	15mm / 5mm / -	100
722 006 060	TSM 6x60 P VZ30 LT A4	40mm / 50mm / 60mm	35mm / 45mm / 55mm	25mm / 15mm / 5mm	100
722 006 080	TSM 6x80 P VZ30 LT A4	40mm / 50mm / 60mm	35mm / 45mm / 55mm	45mm / 35mm / 25mm	100
722 006 100	TSM 6x100 P VZ30 LT A4	40mm / 50mm / 60mm	35mm / 45mm / 55mm	65mm / 55mm / 45mm	100

## Stainless Steel - LT A4

Version with metric female thread M8/M10

Size 6  
Washer-Ø 25,0 mm

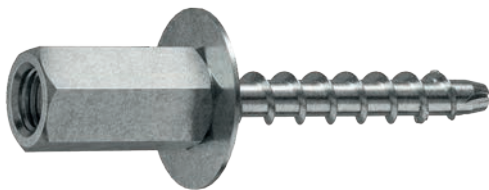
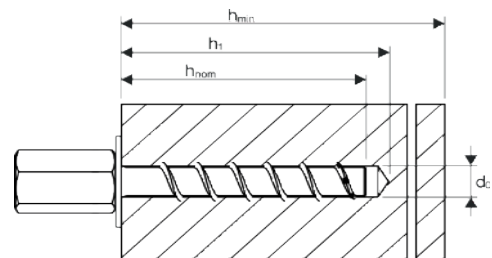

Item nr.	Designation	Depth of drill hole $h_{01} / h_{02} / h_{03}$	Embedment depth of anchor $h_{nom1} / h_{nom2} / h_{nom3}$	Max. thickness of fixture $t_{fix1} / t_{fix2} / t_{fix3}$	Packing Unit
744 006 045	TSM 6x45 K IM 8/10 LT A4	50mm / - / -	45mm / - / -	- / - / -	50

## Stainless Steel - A4

Version with metric external thread <sup>1)</sup>

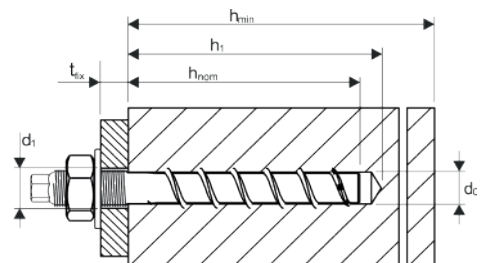

Item nr.	Designation	Depth of drill hole $h_{01} / h_{02} / h_{03}$	Embedment depth of anchor $h_{nom1} / h_{nom2} / h_{nom3}$	Max. thickness of fixture $t_{fix1} / t_{fix2} / t_{fix3}$	Packing Unit
866 008 105	TSM 8x105 M10x30 SW7 A4	55mm / 65mm / 75mm	45mm / 55mm / 65mm	39mm / 29mm / 19mm	50
866 010 140	TSM 10x140 M12x35 SW9 A4	65mm / 85mm / 95mm	55mm / 75mm / 85mm	59mm / 39mm / 29mm	50
866 010 160	TSM 10x160 M12x55 SW9 A4	65mm / 85mm / 95mm	55mm / 75mm / 85mm	79mm / 59mm / 49mm	50

<sup>1)</sup> Technical data for this design can be found in the tables for steel zinc plated.



## Single fastening without fire exposure, Steel

Screw size TSM high performance			TSM 6			TSM 8			TSM 10			TSM 12			TSM 14			
Nominal embedment depth	h <sub>nom</sub>	[mm]	h <sub>nom1</sub>	h <sub>nom2</sub>	h <sub>nom1</sub>	h <sub>nom2</sub>	h <sub>nom3</sub>	h <sub>nom1</sub>	h <sub>nom2</sub>	h <sub>nom3</sub>	h <sub>nom1</sub>	h <sub>nom2</sub>	h <sub>nom3</sub>	h <sub>nom1</sub>	h <sub>nom2</sub>	h <sub>nom3</sub>		
			40	55	45	55	65	55	75	85	65	85	100	75	100	115		
Nominal diameter of drill bit	d <sub>0</sub>	[mm]	6			8			10			12			14			
Depth of drill hole	h <sub>0</sub> min	[mm]	45	60	55	65	75	65	85	95	75	95	110	85	110	125		
Effective anchorage depth	h <sub>ef</sub>	[mm]	31	44	35	43	52	43	60	68	50	67	80	58	79	92		
Diameter of clearance hole in the fixture	d <sub>i</sub> max	[mm]	8			12			14			16			18			
Approved tension load in cracked concrete <sup>1) 2)</sup>	N <sub>zul</sub>	[kN]	1,0	1,9	2,4	4,3	5,7	4,3	7,6	9,2	5,7	9,0	11,7	7,2	11,5	14,5		
Approved shear load in cracked concrete <sup>1) 2)</sup>	V <sub>zul</sub>	[kN]	2,8	4,0	3,4	4,6	6,2	4,6	15,2	18,4	5,8	18,0	23,5	7,2	23,0	28,9		
Approved tension load in non-cracked concrete <sup>1) 2)</sup>	N <sub>zul</sub>	[kN]	1,9	4,3	3,6	5,7	7,6	5,7	9,5	12,4	7,6	12,9	16,8	10,4	16,5	20,7		
Approved shear load in non-cracked concrete <sup>1) 2)</sup>	V <sub>zul</sub>	[kN]	4,0	4,0	4,9	6,6	8,8	6,6	19,4	19,4	8,3	24,0	24,0	10,4	32,0	32,0		
Approved bending resistance	M <sub>zul</sub>	[kN]	6,2			14,9			32,0			64,6			105,7			
Minimum egde distance	C <sub>min</sub>	[mm]	40	40	50			50			50	70	50	70				
Minimum spacing	S <sub>min</sub>	[mm]	40	40	50			50			50	70	50	70				
Minimum base material thickness	h <sub>min</sub>	[mm]	100			100			100	130			120	130	150	130	150	170
Installation torque (with metric connection thread)	T <sub>inst</sub>	[Nm]	10			20			40			60			80			
Maximum torque (with impact screw driver)		[Nm]	160			300			400			650			650			
ETA Seismic C1	C1		Yes	x		Yes	Yes	x	Yes	x		Yes	x		Yes			
ETA Seismic C2 <sup>3)</sup>	C2		x	x		Yes	x		Yes	x		Yes	x		Yes			

## Single fastening under fire exposure, Steel

Screw size TSM high performance			TSM 6			TSM 8			TSM 10			TSM 12			TSM 14		
Nominal embedment depth	h <sub>nom</sub>	[mm]	h <sub>nom1</sub>	h <sub>nom2</sub>	h <sub>nom1</sub>	h <sub>nom2</sub>	h <sub>nom3</sub>	h <sub>nom1</sub>	h <sub>nom2</sub>	h <sub>nom3</sub>	h <sub>nom1</sub>	h <sub>nom2</sub>	h <sub>nom3</sub>	h <sub>nom1</sub>	h <sub>nom2</sub>	h <sub>nom3</sub>	
			40	55	45	55	65	55	75	85	65	85	100	75	100	115	
Approved load under tensile and shear use (F <sub>zul,fi</sub> = N <sub>zul,fi</sub> = V <sub>zul,fi</sub> )																	
Fire resistance class																	
R 30	Approved load	F <sub>zul,fi 30</sub>	[kN]	0,5	0,9	1,2	2,1	2,4	2,1	4,0	4,4	3,0	4,7	6,2	3,8	6,0	7,6
R 60		F <sub>zul,fi 60</sub>	[kN]	0,5	0,8	1,2	1,7	1,7	2,1	3,3	3,0	4,7	5,8	3,8	6,0	7,6	
R 90		F <sub>zul,fi 90</sub>	[kN]	0,5	0,6	1,1			2,1	2,3	3,0	4,2	3,8	5,9			
R 120		F <sub>zul,fi 120</sub>	[kN]	0,4		0,7			1,7			2,4	3,4	3,0	4,8		
R 30		M <sub>zul,fi 30</sub>	[Nm]	0,7			2,4			5,9			12,3			20,4	
R 60		M <sub>zul,fi 60</sub>	[Nm]	0,6			1,8			4,5			9,7			15,9	
R 90		M <sub>zul,fi 90</sub>	[Nm]	0,5			1,2			3,0			7,0			11,6	
R 120		M <sub>zul,fi 120</sub>	[Nm]	0,3			0,9			2,3			5,7			9,4	
Edge distance																	
R 30 to R 120	C <sub>cr,fi</sub>	[mm]	2 x h <sub>ef</sub>														
The edge distance must be at least 300 mm if the fire load attacks from more than one side.																	
Spacing																	
R 30 to R 120	S <sub>cr,fi</sub>	[mm]	4 x h <sub>ef</sub>														
Concrete pry-out failure																	
R 30 to R 120	k	[-]	1,0	1,0			1,0	2,0	1,0	2,0	1,0	2,0	1,0	2,0			
In wet concrete, the embedment depth must be increased by at least 30 mm.																	

<sup>1)</sup> For the determination of the approved loads, the partial safety factor from the approval γM=1,0 was taken into account for material resistance and a partial safety factor γF=1,4 for load actions.

<sup>2)</sup> These values apply without influence of the spacing and edge distances. <sup>3)</sup> C2 only for version zinc plated.



## Single fastening without fire exposure, stainless steel A4

Screw size TSM high performance LT A4			TSM 6			TSM 8			TSM 10		
Nominal embedment depth	$h_{nom}$ [mm]		$h_{nom1}$	$h_{nom2}$	$h_{nom3}$	$h_{nom1}$	$h_{nom2}$	$h_{nom3}$	$h_{nom1}$	$h_{nom2}$	$h_{nom3}$
			35 <sup>3)</sup>	45	55	45	55	65	55	75	85
Nominal diameter of drill bit	$d_o$	[mm]	6			8			10		
Depth of drill hole	$h_o$ min	[mm]	40	50	60	55	65	75	65	85	95
Effective anchorage depth	$h_{ef}$	[mm]	25	34	42	32	41	49	40	57	65
Diameter of clearance hole in the fixture	$d_i$ max	[mm]	8			12			14		
Approved tension load in cracked concrete <sup>1) 2)</sup>	$N_{zul}$	[kN]	1,2	0,7	1,4	1,4	2,6	3,8	2,9	6,2	8,1
Approved shear load in cracked concrete <sup>1) 2)</sup>	$V_{zul}$	[kN]	2,1	4,0	4,0	6,2	7,7	9,7	10,4	17,6	19,4
Approved tension load in non-cracked concrete <sup>1) 2)</sup>	$N_{zul}$	[kN]	1,7	1,9	4,1	4,2	5,7	8,0	5,2	9,1	11,9
Approved shear load in non-cracked concrete <sup>1) 2)</sup>	$V_{zul}$	[kN]	2,9	4,0	4,0	7,7	7,7	9,7	12,9	19,4	19,4
Approved bending resistance	$M_{zul}$	[kNm]	6,2			14,9			32,0		
Minimum edge distance	$C_{min}$	[mm]	35			35			40		
Minimum spacing	$S_{min}$	[mm]	35			35			40		
Minimum base material thickness	$h_{min}$	[mm]	80		100	80	100	120	100	130	
Installation torque (with metric connection thread)	$T_{inst}$	[Nm]	10			20			40		
Maximum torque (with impact screw driver)		[Nm]	160			300			450		
ETA Seismic C1	C1		x	Ja		Ja	x	Ja	Ja	x	Ja

## Single fastening under fire exposure, stainless steel A4

Screw size TSM high performance LT A4			TSM 6			TSM 8			TSM 10			
Nominal embedment depth	$h_{nom}$ [mm]		$h_{nom1}$	$h_{nom2}$	$h_{nom3}$	$h_{nom1}$	$h_{nom2}$	$h_{nom3}$	$h_{nom1}$	$h_{nom2}$	$h_{nom3}$	
			35 <sup>3)</sup>	45	55	45	55	65	55	75	85	
Approved load for tension and shear stress ( $F_{zul,fi} = N_{zul,fi} = V_{zul,fi}$ )												
Fire resistance class												
R 30	Approved load	$F_{zul,fi 30}$	[kN]	0,5	0,4	0,8	0,8	1,4	2,0	1,5	3,3	4,3
R 60		$F_{zul,fi 60}$	[kN]	0,5	0,4	0,8	0,8	1,4	1,7	1,5	3,3	
R 90		$F_{zul,fi 90}$	[kN]	0,5	0,4	0,6	0,8	1,1		1,5	2,3	
R 120		$F_{zul,fi 120}$	[kN]	0,4	0,3	0,4	0,6	0,7		1,2	1,7	
R 30		$M_{zul,fi 30}$	[Nm]	0,7			2,4			5,9		
R 60		$M_{zul,fi 60}$	[Nm]	0,6			1,8			4,5		
R 90		$M_{zul,fi 90}$	[Nm]	0,5			1,2			3,0		
R 120		$M_{zul,fi 120}$	[Nm]	0,3			0,9			2,3		
Edge distance												
R 30 to R 120		$C_{cr,fi}$	[mm]	$2 \times h_{ef}$								
The edge distance must be at least 300 mm if the fire load attacks from more than one side.												
Spacing												
R 30 to R 120	$S_{cr,fi}$	[mm]	$4 \times h_{ef}$									
Concrete pry-out failure												
R 30 to R 120	k	[-]	1,0	1,6	2,1	2,8	2,5					
In wet concrete, the embedment depth must be increased by at least 30 mm.												

<sup>1)</sup> For the determination of the approved loads, the partial safety factor from the approval  $\gamma_M=1,0$  was taken into account for material resistance and a partial safety factor  $\gamma_F=1,4$  for load actions.

<sup>2)</sup> These values apply without influence of the spacing and edge distances. <sup>3)</sup> Only for multiple use under dry conditions.

## Multiple fastening without fire exposure, Steel

Screw size TSM high performance			TSM 5	TSM 6	
Nominal embedment depth	$h_{nom}$	[mm]	35	35	55
Nominal diameter of drill bit	$d_0$	[mm]	5	6	
Depth of drill hole	$h_0$ min	[mm]	40	40	60
Effective anchorage depth	$h_{ef}$	[mm]	27	27	44
Diameter of clearance hole in the fixture	$d_f$ max	[mm]	7	8	
Approved tension load in cracked concrete <sup>1),2)</sup>	$N_{zul}$	[kN]	0,6	1,4	3,6
Approved shear load in cracked concrete <sup>1),2)</sup>	$V_{zul}$	[kN]	1,9	2,3	4,8
Approved tension load in non-cracked concrete <sup>1),2)</sup>	$N_{zul}$	[kN]	0,6	1,4	3,6
Approved shear load in non-cracked concrete <sup>1),2)</sup>	$V_{zul}$	[kN]	2,5	3,3	4,0
Minimum edge distance	$C_{min}$	[mm]	35	35	40
Minimum spacing	$S_{min}$	[mm]	35	35	40
Minimum base material thickness	$h_{min}$	[mm]	80	80	100
Installation torque (with metric connection thread)	$T_{inst}$	[Nm]	8	10	
Maximum torque (with impact screw driver)		[Nm]	110	160	

<sup>1)</sup> For the determination of the approved loads, the partial safety factor from the approval  $\gamma_M=1,0$  was taken into account for material resistance and a partial safety factor  $\gamma_F=1,4$  for load actions.

<sup>2)</sup> These values apply without influence of the space and edge distancing.

## Multiple fastening under fire exposure, Steel

Screw size TSM high performance				TSM 5	TSM 6	
Nominal embedment depth		$h_{nom}$	[mm]	$h_{nom1}$	$h_{nom1}$	$h_{nom2}$
				35	35	55
Approved load under tensile and shear use ( $F_{zul,fi} = N_{zul,fi} = V_{zul,fi}$ )						
Fire resistance class						
R 30	Approved load	$F_{zul,fi 30}$	[kN]	0,4	0,8	0,9
R 60		$F_{zul,fi 60}$	[kN]	0,4	0,8	
R 90		$F_{zul,fi 90}$	[kN]	0,4	0,6	
R 120		$F_{zul,fi 120}$	[kN]	0,3	0,4	
R 30		$M_{zul,fi 30}$	[Nm]	0,5	0,7	
R 60		$M_{zul,fi 60}$	[Nm]	0,4	0,6	
R 90		$M_{zul,fi 90}$	[Nm]	0,2	0,5	
R 120		$M_{zul,fi 120}$	[Nm]	0,2	0,3	
Edge distance						
R 30 to R 120		$C_{cr,fi}$	[mm]	$2 \times h_{ef}$		
The edge distance must be at least 300 mm if the fire load attacks from more than one side.						
Spacing						
R 30 to R 120		$S_{cr,fi}$	[mm]	$4 \times h_{ef}$		
Concrete pry-out failure						
R 30 to R 120		k	[-]	1,0		
In wet concrete, the embedment depth must be increased by at least 30 mm.						

## Multiple fastening in prestressed hollow core slabs without fire exposure, steel

Screw size TSM high performance	TSM 6		
Bottom flange thickness	$d_b$	[mm]	$\geq 25$ $\geq 30$ $\geq 35$
Nominal diameter of drill bit	$d_0$	[mm]	6
Depth of drill hole	$h_b$ min	[mm]	30   35   40
Clearance hole diameter	$d_f$ max	[mm]	8
Approved tension load <sup>1)</sup>	$F_{zul}$	[kN]	0,5   1,0   1,4
Minimum edge distance	$C_{min}$	[mm]	100
Minimum spacing	$S_{min}$	[mm]	100
Minimum distance between anchor groups	$a_{min}$	[mm]	100
Core distance	$l_c$ min	[mm]	100
Prestressing steel distance	$l_p$ min	[mm]	100
Distance between anchor position & prestressing steel	$a_p$ min	[mm]	50
Hollow core width (w)	(w/e) max [mm]		4,2
Bridge width (e)			
Installation torque	$T_{inst}$	[Nm]	10
Max. torquet (for impact screw driver)		[Nm]	160

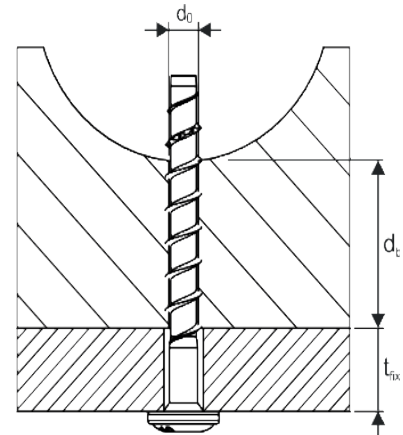

<sup>1)</sup> For the determination of the approved loads, the partial safety factor from the approval  $\gamma_M=1,0$  was taken into account for material resistance and a partial safety factor  $\gamma_F=1,4$  for load actions.

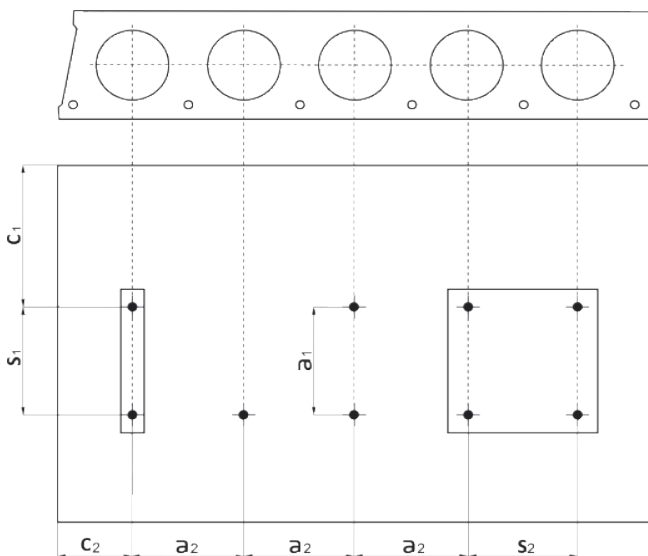

$C_1, C_2$  = Edge distance  
 $S_1, S_2$  = Spacing  
 $a_1, a_2$  = Distance between anchor groups

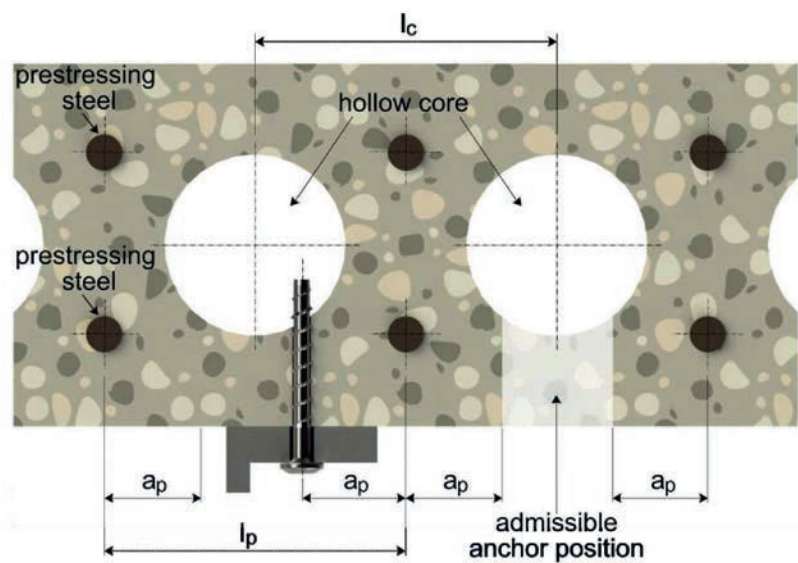

$l_c$  = Core distance  
 $l_p$  = Prestressing steel distance  
 $a_p$  = Distance between anchor position & prestressing steel



## Masonry

### Solid calcium silicate brick KS acc. to DIN EN 771-2:2015-11

#### Single fastening without fire exposure, steel

Screw size TSM high performance			TSM 5		TSM 6		TSM 8		TSM 10		
Nominal embedment depth	$h_{nom}$	[mm]	$h_{nom1}$	$h_{nom1}$	$h_{nom2}$	$h_{nom1}$	$h_{nom2}$	$h_{nom1}$	$h_{nom2}$		
			35	35	55	45	65	55	75		
Nominal diameter of drill bit	$d_0$	[mm]	5	6		8		10			
Cutting diameter of drill bit	$d_{cut} \leq$	[mm]	5,40	6,40		8,45		10,45			
Depth of drill hole	$h_0 \geq$	[mm]	55	55	75	65	85	75	95		
Diameter of clearance hole in the fixture	$d_f \leq$	[mm]	7	8		12		14			
Torque for manual installation	$max. T_{inst}$	[Nm]	6	11		27		37	46		
Impact screw driver	$T_{imp,max}$	[Nm]	185			300					
Minimum wall thickness	$h_{min}$	[mm]	240								
Minimum edge distance	$C_{min}$	[mm]	80								
Minimum spacing	$S_{min}$	[mm]	80								
Distance to the horizontal joints	$C_{\perp}$	[mm]	$\geq 35$								
Distance to the vertical joints	$C_{\parallel}$	[Nm]	$\geq 80$								

Nomenclature	Dimensions [mm]	Bulk density [kg/dm <sup>3</sup> ]	Compressive strength [N/mm <sup>2</sup> ]	Screw size		TSM 5		TSM 6		TSM 8		TSM 10	
				$h_{nom}$	[mm]	$h_{nom1}$	$h_{nom1}$	$h_{nom2}$	$h_{nom1}$	$h_{nom2}$	$h_{nom1}$	$h_{nom2}$	
						35	35	55	45	65	55	75	
KS 20 - 2,0 - NF	L:240 B: 115 H:71	2	26	$N_{zul}$	[kN]	1,0	0,9	1,4	1,2	1,2	1,1	1,3	
				$V_{zul}$	[kN]	0,9							
			30	$N_{zul}$	[kN]	1,1	1,0	1,5	1,3	1,3	1,1	1,4	
				$V_{zul}$	[kN]	1,0							
			35	$N_{zul}$	[kN]	1,1	1,1	1,6	1,4	1,4	1,3	1,5	
				$V_{zul}$	[kN]	1,1							
			38	$N_{zul}$	[kN]	1,2	1,1	1,7	1,4	1,5	1,3	1,5	
				$V_{zul}$	[kN]	1,1							

For the determination of the approved load, the partial safety factor from the approval  $\gamma_{M,2.5}$  was taken into account on the resistance side and a partial safety factor  $\gamma_{M,1.4}$  on the action side. The specified values apply regardless of edge and center distances. The specified values apply to single fastening with  $f_{vk,0.15}$  [N/mm<sup>2</sup>] and  $\sigma_{s,0.2}$  [N/mm<sup>2</sup>].

#### Single fastening under fire exposure, steel

Nomenclature	Dimensions [mm]	Bulk density [kg/dm <sup>3</sup> ]	Fire resistance class	Screw size		TSM 5		TSM 6	
				$h_{nom}$	[mm]	$h_{nom1}$	$h_{nom1}$	$h_{nom2}$	
				$F_{zul,fi} = N_{zul,fi} = V_{zul,fi}$		35	35	55	
KS 20 - 2,0 - NF	L: 240 B: 115 H: 71	2	R30	$F_{zul,fi30}$	[kN]	1,1	0,3	0,7	
			R60	$F_{zul,fi60}$	[kN]	0,8	0,3	0,7	
			R90	$F_{zul,fi90}$	[kN]	0,5	0,3	0,6	
			R120	$F_{zul,fi120}$	[kN]	0,3	0,2	0,4	
			R30	$M_{zul,fi30}^0$	[kN]	0,8	1,2	1,2	
			R60	$M_{zul,fi60}^0$	[kN]	0,5	0,9	0,9	
			R90	$M_{zul,fi90}^0$	[kN]	0,3	0,5	0,5	
			R120	$M_{zul,fi120}^0$	[kN]	0,2	0,3	0,3	

To determine the approved load, the partial safety factor from the approval  $\gamma_{M,fi} = 1.0$  was taken into account on the resistance side. The specified values apply irrespective of edge and center distances. The specified values apply for single fastening with  $f_{vk,0.15}$  [N/mm<sup>2</sup>] and  $\sigma_{s,0.2}$  [N/mm<sup>2</sup>].



## Masonry

# Silka XL solid calcium silicate brick KS 12DF acc. to DIN EN 771-2:2015-11

### Single fastening without fire exposure, steel

Screw size TSM high performance		TSM 5	TSM 6	TSM 8	TSM 10
Nominal embedment depth	$h_{nom}$ [mm]	$h_{nom1}$	$h_{nom1}$	$h_{nom1}$	$h_{nom1}$
		$h_{nom2}$	$h_{nom2}$	$h_{nom2}$	$h_{nom2}$
Nominal diameter of drill bit	$d_0$ [mm]	5	6	8	10
Cutting diameter of drill bit	$d_{cut} \leq$ [mm]	5,40	6,40	8,45	10,45
Depth of drill hole	$h_0 \geq$ [mm]	55	55	75	75
Diameter of clearance hole in the fixture	$d_f \leq$ [mm]	7	8	12	14
Torque for manual installation	$T_{inst}^{max}$ [Nm]	6	10	25	45
Torque for rotary screw driver	$T_{imp,max}$ [Nm]	8	10	-	
Impact screw driver	$T_{imp,max}$ [Nm]	-		185	300
Minimum wall thickness	$h_{min}$ [mm]	175			
Minimum edge distance	$c_{min}$ [mm]	80			
Minimum spacing	$s_{min}$ [mm]	80			
Distance to the horizontal joints	$c_{j,\perp}$ [mm]	$\geq 40$			
Distance to the vertical joints	$c_{j,\parallel}$ [mm]	$\geq 80$			

Nomenclature	Dimensions [mm]	Bulk density [kg/dm <sup>3</sup> ]	Compressive strength [N/mm <sup>2</sup> ]	Screw size		TSM 5		TSM 6		TSM 8		TSM 10	
				$h_{nom}$	[mm]	$h_{nom1}$	$h_{nom1}$	$h_{nom2}$	$h_{nom1}$	$h_{nom2}$	$h_{nom1}$	$h_{nom2}$	
						35	35	55	45	65	55	75	
KS - R (P) 20 - 2,0 - 12 DF	L: 498 B: 175 H: 248	1,8	14	$N_{zul}$	[kN]	0,7	0,7	1,2	1,8	1,8	1,8	1,9	
				$V_{zul}$	[kN]	0,9	0,9	2,4	0,9	2,1	1,7	2,4	
			15	$N_{zul}$	[kN]	0,7	0,7	1,2	1,9	1,9	1,9	2,0	
				$V_{zul}$	[kN]	0,9	0,9	2,4	0,9	2,2	1,7	2,4	
			20	$N_{zul}$	[kN]	0,8	0,8	1,4	2,1	2,1	2,2	2,3	
				$V_{zul}$	[kN]	1,1	1,1	2,8	1,1	2,6	2,0	3,4	

For the determination of the approved load, the partial safety factor from the approval  $\gamma_{M,2.5}$  was taken into account on the resistance side and a partial safety factor  $\gamma_F=1.4$  on the action side. The specified values apply regardless of edge and center distances. The specified values apply to single fastening with  $f_{vk,0.15}$  [N/mm<sup>2</sup>] and  $\sigma_{s,0.2}$  [N/mm<sup>2</sup>].

### Single fastening under fire exposure, steel

Nomenclature	Dimensions [mm]	Bulk density [kg/dm <sup>3</sup> ]	Fire resistance class	Screw size		TSM 5		TSM 6	
				$h_{nom}$	[mm]	$h_{nom1}$	$h_{nom1}$	$h_{nom2}$	
				$F_{zul,fi} = N_{zul,fi} = V_{zul,fi}$		35	35	55	
KS - R (P) 20 - 2,0 - 12 D	L: 498 B: 175 H: 248	1,8	R30	$F_{zul,fi30}$	[kN]	1,1	0,3	0,7	
			R60	$F_{zul,fi60}$	[kN]	0,8	0,3	0,7	
			R90	$F_{zul,fi90}$	[kN]	0,5	0,3	0,6	
			R120	$F_{zul,fi120}$	[kN]	0,3	0,2	0,4	
			R30	$M_{zul,fi30}^0$	[kN]	0,8	1,2	1,2	
			R60	$M_{zul,fi60}^0$	[kN]	0,5	0,9	0,9	
			R90	$M_{zul,fi90}^0$	[kN]	0,3	0,5	0,5	
			R120	$M_{zul,fi120}^0$	[kN]	0,2	0,3	0,3	

To determine the approved load, the partial safety factor from the approval  $\gamma_{M,fi}$  = 1.0 was taken into account on the resistance side. The specified values apply irrespective of edge and center distances. The specified values apply for single fastening with  $f_{vk,0.15}$  [N/mm<sup>2</sup>] and  $\sigma_{s,0.2}$  [N/mm<sup>2</sup>].

## Masonry

# Perforated calcium silicate brick KSL 3DF acc. to DIN EN 771-2:2015-11

### Single fastening without fire exposure, steel

Screw size TSM high performance		TSM 5	TSM 6	TSM 8	TSM 10
Nominal embedment depth	$h_{nom}$ [mm]	$h_{nom1}$	$h_{nom1}$   $h_{nom2}$	$h_{nom1}$   $h_{nom2}$	$h_{nom1}$   $h_{nom2}$
		35	35   55	45   65	55   75
Nominal diameter of drill bit	$d_0$ [mm]	5	6	8	10
Cutting diameter of drill bit	$d_{cut} \leq$ [mm]	5,40	6,40	8,45	10,45
Depth of drill hole	$h_0 \geq$ [mm]	55	55   75	65   85	75   95
Diameter of clearance hole in the fixture	$d_f \leq$ [mm]	7	8	12	14
Torque for manual installation	$T_{inst}^{max}$ [Nm]	3	4	9	9
Torque for rotary screw driver	$T_{imp,max}$ [Nm]	9	11	-	
Impact screw driver	$T_{imp,max}$ [Nm]	-		100	200
Minimum wall thickness	$h_{min}$ [mm]	175			
Minimum edge distance	$C_{min}$ [mm]	58			
Minimum spacing	$S_{min}$ [mm]	80			
Distance to the horizontal joints	$C_{j \perp}$ [mm]	$\geq 35$			
Distance to the vertical joints	$C_{j \parallel}$ [mm]	$\geq 58$			

Nomenclature	Dimensions [mm]	Bulk density [kg/dm <sup>3</sup> ]	Compressive strength [N/mm <sup>2</sup> ]	Screw size		TSM 5		TSM 6		TSM 8		TSM 10	
				$h_{nom}$	[mm]	$h_{nom1}$	$h_{nom1}$	$h_{nom2}$	$h_{nom1}$	$h_{nom2}$	$h_{nom1}$	$h_{nom2}$	
						35	35	55	45	65	55	75	
SWKV KSL 12 - 1,6 3DF	L: 240 B: 175 H: 113	1,5	17	$N_{zul}$	[kN]	0,3		0,5		0,6			
				$V_{zul}$	[kN]	0,5		0,6					
			20	$N_{zul}$	[kN]	0,4		0,5		0,7			
				$V_{zul}$	[kN]	0,5		0,7					
			25	$N_{zul}$	[kN]	0,4		0,6		0,9			
				$V_{zul}$	[kN]	0,6		0,8					

For the determination of the approved load, the partial safety factor from the approval  $\gamma_{M,2.5}$  was taken into account on the resistance side and a partial safety factor  $\gamma_F=1.4$  on the action side. The specified values apply regardless of edge and center distances. The specified values apply to single fastening with  $f_{v,sk}$ :0.15 [N/mm<sup>2</sup>] and  $\sigma_{s,sk}$ :0.2 [N/mm<sup>2</sup>].

### Single fastening under fire exposure, steel

Nomenclature	Dimensions [mm]	Bulk density [kg/dm <sup>3</sup> ]	Fire resistance class	Screw size		TSM 5		TSM 6	
				$h_{nom}$	[mm]	$h_{nom1}$	$h_{nom1}$	$h_{nom2}$	
				$F_{zul,fi} = N_{zul,fi} = V_{zul,fi}$		35	35	55	
SWKV KSL 12 - 1,6 3DF	L: 240 B: 175 H: 113	1,5	R30	$F_{zul,fi30}$	[kN]	0,7	0,1	0,2	
			R60	$F_{zul,fi60}$	[kN]	0,6	0,1	0,2	
			R90	$F_{zul,fi90}$	[kN]	0,4	0,1	0,2	
			R120	$F_{zul,fi120}$	[kN]	0,3	0,1	0,2	
			R30	$M_{zul,fi30}^0$	[kN]	0,5	0,8	0,8	
			R60	$M_{zul,fi60}^0$	[kN]	0,4	0,6	0,6	
			R90	$M_{zul,fi90}^0$	[kN]	0,2	0,4	0,4	
			R120	$M_{zul,fi120}^0$	[kN]	0,2	0,3	0,3	

To determine the approved load, the partial safety factor from the approval  $\gamma_{M,fi}$  = 1.0 was taken into account on the resistance side. The specified values apply irrespective of edge and center distances. The specified values apply for single fastening with  $f_{v,sk}$ :0.15 [N/mm<sup>2</sup>] and  $\sigma_{s,sk}$ :0.2 [N/mm<sup>2</sup>].



## Masonry

### Solid clay brick MZ acc. to DIN EN 771-1:2015-11

#### Single fastening without fire exposure, steel

Screw size TSM high performance		TSM 5	TSM 6	TSM 8	TSM 10
Nominal embedment depth	$h_{nom}$ [mm]	$h_{nom1}$	$h_{nom1}$   $h_{nom2}$	$h_{nom1}$   $h_{nom2}$	$h_{nom1}$   $h_{nom2}$
		35	35   55	45   65	55   75
Nominal diameter of drill bit	$d_o$ [mm]	5	6	8	10
Cutting diameter of drill bit	$d_{cut} \leq$ [mm]	5,40	6,40	8,45	10,45
Depth of drill hole	$h_o \geq$ [mm]	55	55   75	65   85	75   95
Diameter of clearance hole in the fixture	$d_f \leq$ [mm]	7	8	12	14
Torque for manual installation	$T_{inst}$ [Nm]	2	3	16	23
Torque for rotary screw driver	$T_{imp,max}$ [Nm]	4	9	14	-
Impact screw driver	$T_{imp,max}$ [Nm]	-			185
Minimum wall thickness	$h_{min}$ [mm]	240			
Minimum edge distance	$c_{min}$ [mm]	80			
Minimum spacing	$s_{min}$ [mm]	80			
Distance to the horizontal joints	$c_{j,\perp}$ [mm]	$\geq 35$			
Distance to the vertical joints	$c_{j,\parallel}$ [mm]	$\geq 80$			

Nomenclature	Dimensions [mm]	Bulk density [kg/dm <sup>3</sup> ]	Compressive strength [N/mm <sup>2</sup> ]	Screw size		TSM 5		TSM 6		TSM 8		TSM 10	
				$h_{nom}$	[mm]	$h_{nom1}$	$h_{nom1}$   $h_{nom2}$	$h_{nom1}$   $h_{nom2}$	$h_{nom1}$   $h_{nom2}$	$h_{nom1}$   $h_{nom2}$	$h_{nom1}$   $h_{nom2}$		
						35	35	55	45	65	55	75	
MZ 20 - 2,0 - NF	L:240 B: 115 H:71	2,1	21	$N_{zul}$ [kN]		0,5		0,7		0,9	0,9		
				$V_{zul}$ [kN]		0,6				0,8			
			25	$N_{zul}$ [kN]		0,5		0,7		1,0	1,0		
				$V_{zul}$ [kN]		0,7				0,9			
			30	$N_{zul}$ [kN]		0,5		0,8		1,1	1,1		
				$V_{zul}$ [kN]		0,7				0,9			
			31	$N_{zul}$ [kN]		0,5		0,8		1,1	1,1		
				$V_{zul}$ [kN]		0,7				0,7	0,9		

For the determination of the approved load, the partial safety factor from the approval  $\gamma_{M1}=2.5$  was taken into account on the resistance side and a partial safety factor  $\gamma_F=1.4$  on the action side. The specified values apply regardless of edge and center distances. The specified values apply to single fastening with  $f_{vko}=0.15$  [N/mm<sup>2</sup>] and  $\sigma_{gr}=0.2$  [N/mm<sup>2</sup>].

#### Single fastening under fire exposure, steel

Nomenclature	Dimensions [mm]	Bulk density [kg/dm <sup>3</sup> ]	Fire resistance class	Screw size		TSM 5		TSM 6	
				$h_{nom}$	[mm]	$h_{nom1}$	$h_{nom1}$   $h_{nom2}$	$h_{nom1}$   $h_{nom2}$	
				$F_{zul,fi} = N_{zul,fi} = V_{zul,fi}$		35	35	55	
MZ 20 - 2,0 - NF	L: 240 B: 115 H: 71	2,1	R30	$F_{zul,fi30}$ [kN]		1,1	0,2	0,3	
			R60	$F_{zul,fi60}$ [kN]		0,8	0,2	0,3	
			R90	$F_{zul,fi90}$ [kN]		0,5	0,2	0,3	
			R120	$F_{zul,fi120}$ [kN]		0,3	0,2	0,2	
			R30	$M_{zul,fi30}^0$ [kN]		0,8	1,2	1,2	
			R60	$M_{zul,fi60}^0$ [kN]		0,5	0,9	0,9	
			R90	$M_{zul,fi90}^0$ [kN]		0,3	0,5	0,5	
			R120	$M_{zul,fi120}^0$ [kN]		0,2	0,3	0,3	

To determine the approved load, the partial safety factor from the approval  $\gamma_{M,fi}=1.0$  was taken into account on the resistance side. The specified values apply irrespective of edge and center distances. The specified values apply for single fastening with  $f_{vko}=0.15$  [N/mm<sup>2</sup>] and  $\sigma_{gr}=0.2$  [N/mm<sup>2</sup>].

## Masonry Solid light weight concrete brick acc. to DIN EN 771-3:2015-11

### Single fastening without fire exposure, steel

Screw size TSM high performance			TSM 8	TSM 10
Nominal embedment depth	$h_{nom}$	[mm]	$h_{nom2}$	$h_{nom2}$
			65	75
Nominal diameter of drill bit	$d_0$	[mm]	8	10
Cutting diameter of drill bit	$d_{cut} \leq$	[mm]	8,45	10,45
Depth of drill hole	$h_0 \geq$	[mm]	85	95
Diameter of clearance hole in the fixture	$d_f \leq$	[mm]	12	14
Torque for manual installation	$max. T_{inst}$	[Nm]	6	5
Torque for rotary screw driver	$T_{imp,max}$	[Nm]	10	14
Minimum wall thickness	$h_{min}$	[mm]	240	
Minimum edge distance	$C_{min}$	[mm]	80	
Minimum spacing	$S_{min}$	[mm]	80	
Distance to the horizontal joints	$C_{j\perp}$	[mm]	$\geq 35$	
Distance to the vertical joints	$C_{j\parallel}$	[mm]	$\geq 80$	

Nomenclature	Dimensions [mm]	Bulk density [kg/dm <sup>3</sup> ]	Fire resistance class	Screw size		TSM 8	TSM 10
				$h_{nom}$	[mm]	$h_{nom2}$	$h_{nom2}$
						65	75
VBL 4 - 1,0 2 DF	L: 240 B: 115 H: 113	1,5	4	$N_{zul}$	[kN]	0,2	0,3
				$V_{zul}$	[kN]	0,7	0,9
			5	$N_{zul}$	[kN]	0,2	0,4
				$V_{zul}$	[kN]	0,7	1,1

For the determination of the approved load, the partial safety factor from the approval  $\gamma_M=2,5$  was taken into account on the resistance side and a partial safety factor  $\gamma_E=1,4$  on the action side. The specified values apply regardless of edge and center distances. The specified values apply to single fastening with  $f_{wd}=0,15$  [N/mm<sup>2</sup>] and  $\sigma_d=0,2$  [N/mm<sup>2</sup>].

# Installation Instructions

## Installation instructions for concrete

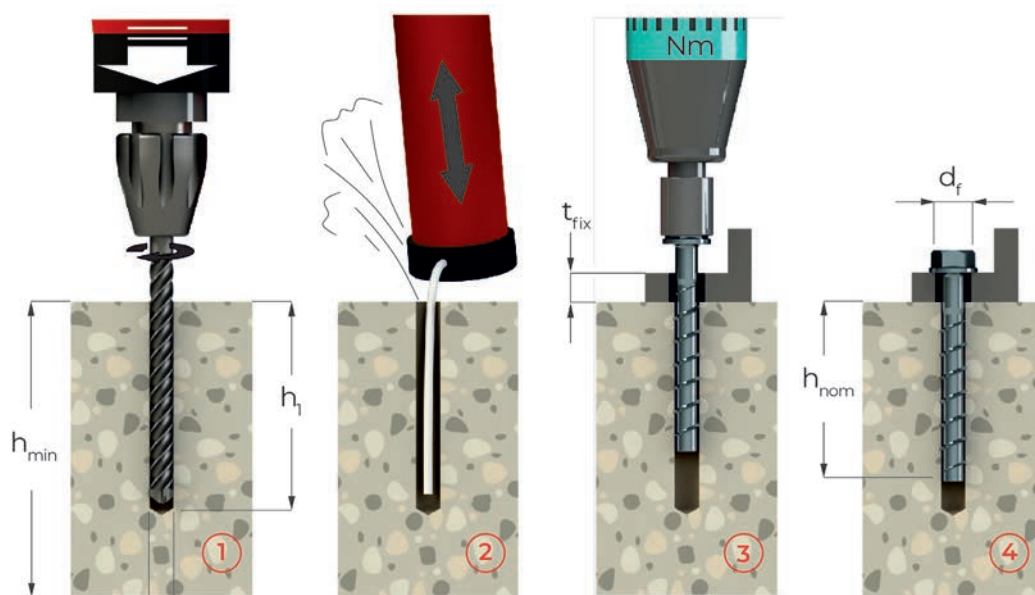

- 1) Create borehole.
- 2) Thoroughly clean borehole.
- 3) Screw in concrete screw TOGE TSM High Performance.
- 4) The screw head must rest completely on the attachment.

## Installation instructions with adjustment for sizes 6 to 14

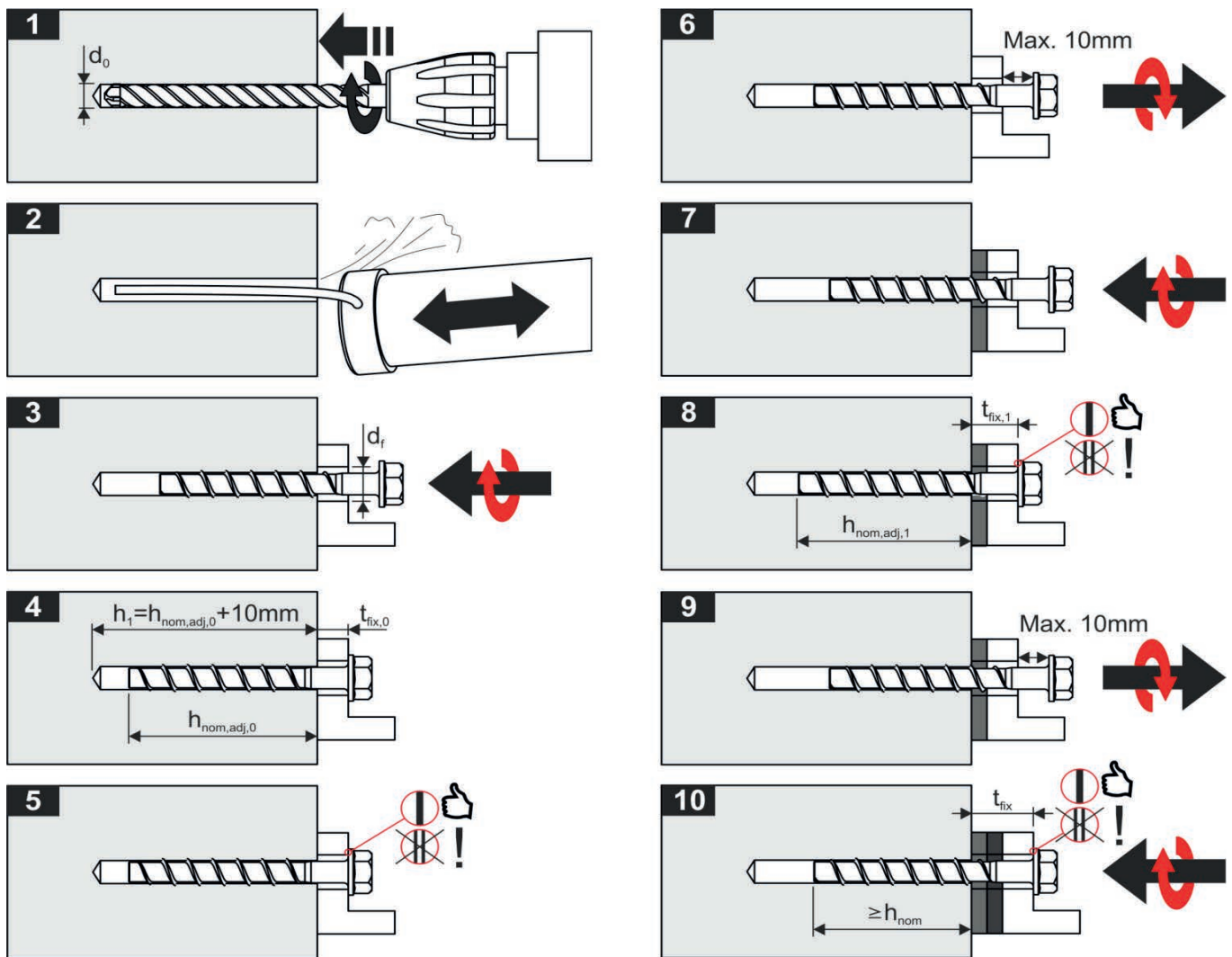

### Important - please note during adjustment:

- The anchor may be adjusted maximum two times while the anchor may turn back at most 10 mm.
- The total allowed thickness of shims added during the adjustment process is 10 mm.
- The final embedment depth after adjustment process must be equal or longer than  $h_{nom}$ .

## Installation instructions for prestressed hollow core slabs

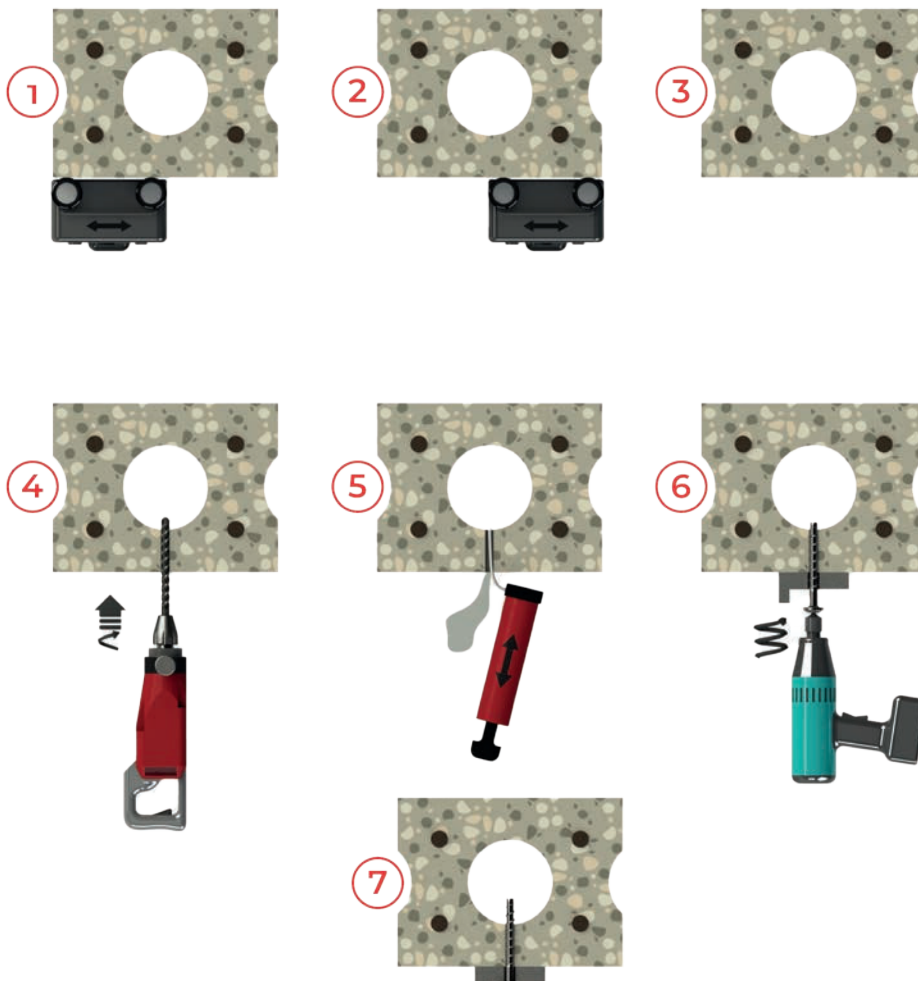

- 1) - 3) Locate prestressing steel with the reinforcement bar detector and mark the location.
- 4) Create hole in the permissible anchoring area.
- 5) Clean hole.
- 6) Screw in concrete screw.
- 7) Screw head must fully contact the fixture.



## Installation Instructions for Masonry

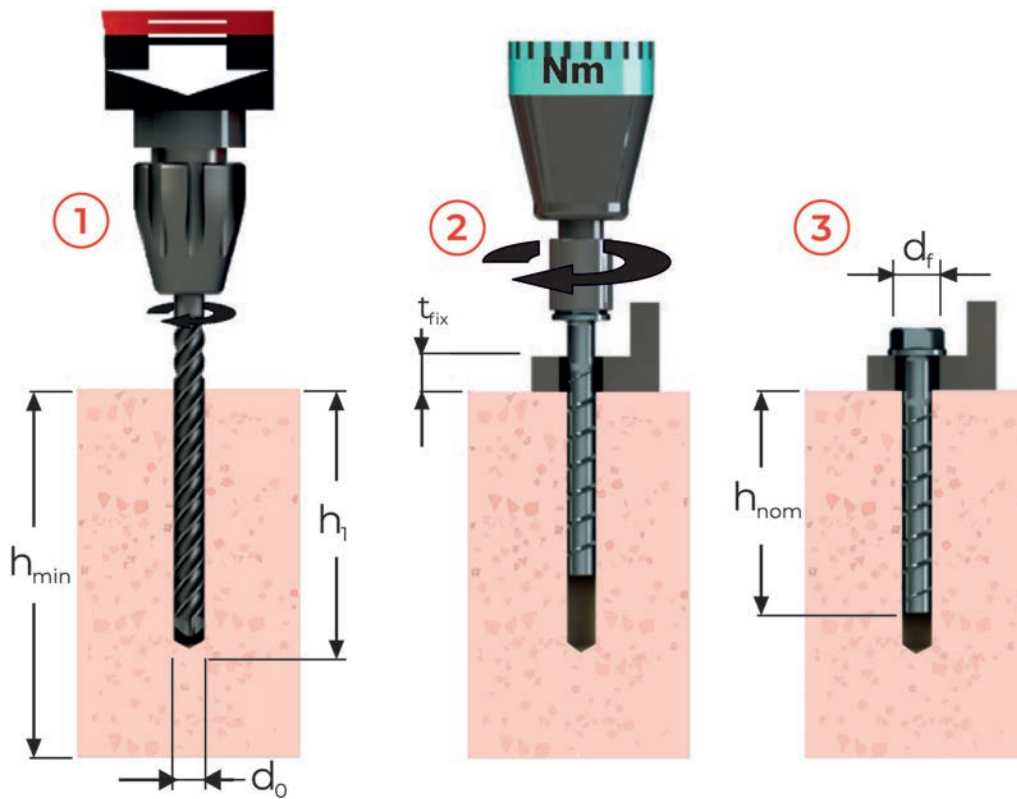

- 1) Drill hole in hammer or rotary mode.
- 2) Screw in with impact screw driver, cordless screw driver or wrench according to the respective stone and size.
- 3) The head must be undamaged and in contact with the fixture. It must not be possible to turn the screw,  $T_{inst}$  max. must not be exceeded.

## Possible installation options in masonry

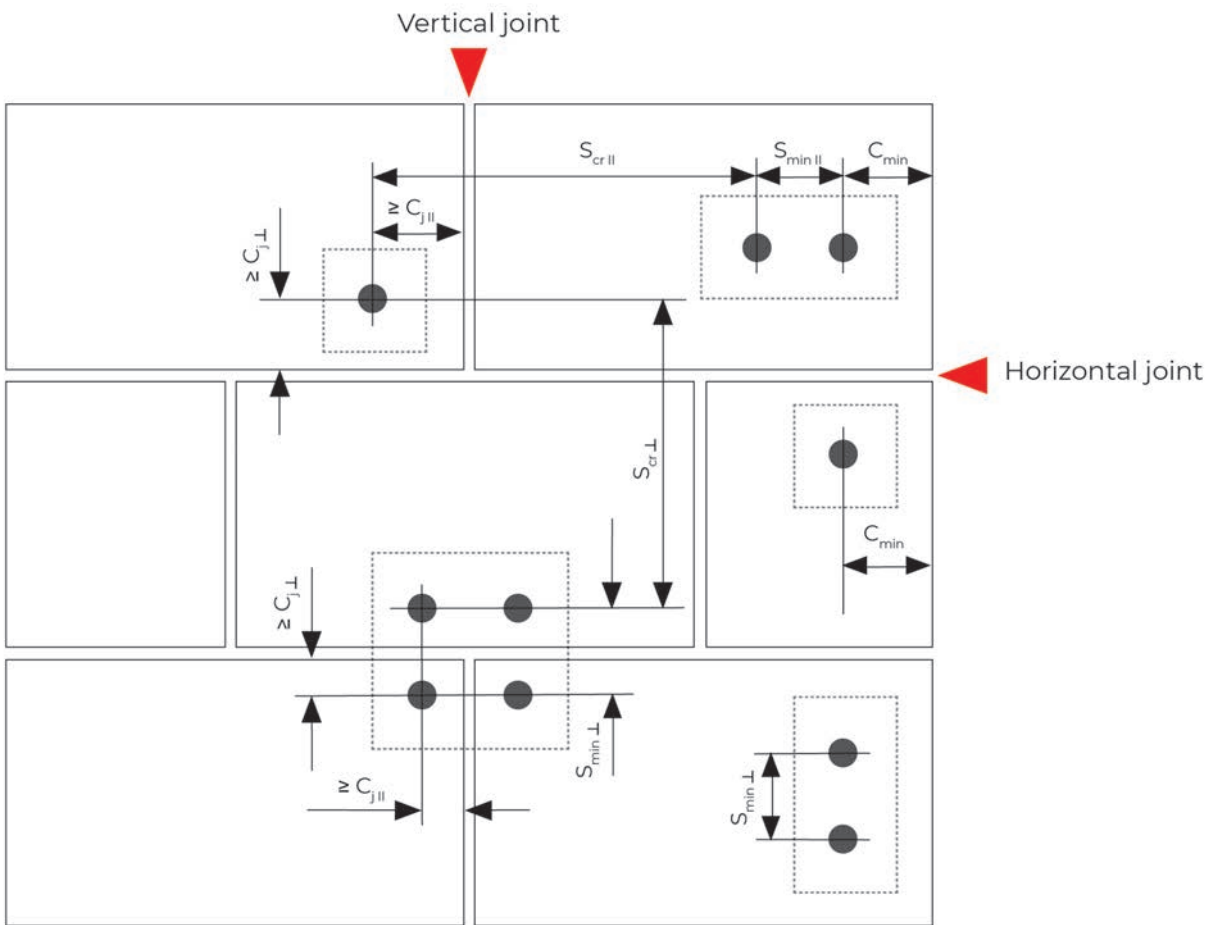

$C_{\min}$  = Minimum edge distance to the free edge of the wall

$C_{j\parallel}$  = Distance to vertical joints

$C_{j\perp}$  = Distance to horizontal joints

$S_{\min\parallel}$  = Minimum spacing parallel to horizontal joint

$S_{\min\perp}$  = Minimum spacing perpendicular to horizontal joint

$S_{cr\parallel}$  = Characteristic spacing parallel to horizontal joint

$S_{cr\perp}$  = Characteristic spacing perpendicular to horizontal joint