

20²⁴₂₅

**PRODUCT
CATALOGUE**



TOGE Product catalogue 2024 / 2025

PRODUCT OVERVIEW

Find the right product
for your needs



01 TOGE TSM High Performance

**Concrete screw –
even for heavy loads**

Page 7 – 32

NEW



02 TOGE TSM ECO

**The economical
concrete screw**

Page 33 – 40



03 TOGE TSM BC ST

**Concrete screw for
temporary fixation**

Page 41 – 47

NEW



04 TOGE TSM Multiground

**Female threaded screw
for various substrates**

Page 49 – 55



05 TOGE TSM L

**Short concrete screw for
drywall constructions**

Page 57 – 65



06 TOGE TSM PB

**Aerated
concrete screw**

Page 67 – 72



07 TOGE TIS

**Insulating screw
for cold-, heat- and
fire-protection**

Page 73 – 85



08 TOGE TID

**Insulating anchor
for cold-, heat- and
fire-protection**

Page 87 – 95



09 TOGE TSM A

Asphalt screw

Page 97 – 104



10 TOGE TSM High Performance

**Adhesive screw
anchor**

Page 105 – 115



11 TOGE TSM B

**Crash barrier
anchor**

Page 117 – 124



ONLINE

**Find more
products on**

[toge.de](https://www.toge.de)

- ✓ Approved
- Suitable



Concrete screw TSM High Performance
 Concrete screw TSM Eco
 Concrete screw TSM BC ST
 Female threaded screw TSM Multiground
 Concrete screw TSM L
 Aerated concrete screw TSM PB
 Insulating screw TIS
 Insulating anchor TID
 Asphalt screw TSM A
 Adhesive screw anchor TSM HP with mortar
 Crash barrier anchor TSM B

Application examples

Concrete

Facade substructures	✓	✓								✓
Steel girders / Steel structures	✓	✓								✓
Railing	✓	✓								✓
Handrails	✓	✓		✓						✓
Shelving systems	✓	✓								✓
Cable ducts / cable clamps	✓	✓		✓	✓					✓
Piping / Pipe clamps	✓	✓		✓	✓					✓
Ventilation ducts	✓	✓		✓	✓					✓
Ceiling suspensions	✓	✓		✓	✓					✓
Lightweight and drywall	✓				✓					
Insulations							✓	✓		
Temporary construction site safety	✓		✓							
Crash barriers										✓

Solid brick masonry

Facade substructures	✓									
Cable ducts / cable clamps	✓									
Piping / Pipe clamps	✓									
Ventilation ducts	✓									
Insulations							○	○		

Asphalt

Traffic signs										○
Protective devices										○
Crash protection systems										○
Speed bumpers										○
Shopping cart canopies										○
E-Charge Stations										○
Crash barriers										○



Concrete screw TSM High Performance
 Concrete screw TSM Eco
 Concrete screw TSM BC ST
 Female threaded screw TSM Multiground
 Concrete screw TSM L
 Aerated concrete screw TSM PB
 Insulating screw TIS
 Insulating anchor TID
 Asphalt screw TSM A
 Adhesive screw anchor TSM HP with mortar
 Crash barrier anchor TSM B

Application examples

Aerated concrete

Light cabinets	<input type="radio"/>
Light shelves	<input type="radio"/>
Substructures made of wood or metal	<input type="radio"/>
Metal rails	<input type="radio"/>

Steel – zinc flake coated

Steel

Stainless steel – LT A4



We are proud of our unique product range

As a specialist in concrete screws, we produce more than 600 different product types in this category in different materials and a variety of designs.

SIDE NOTE

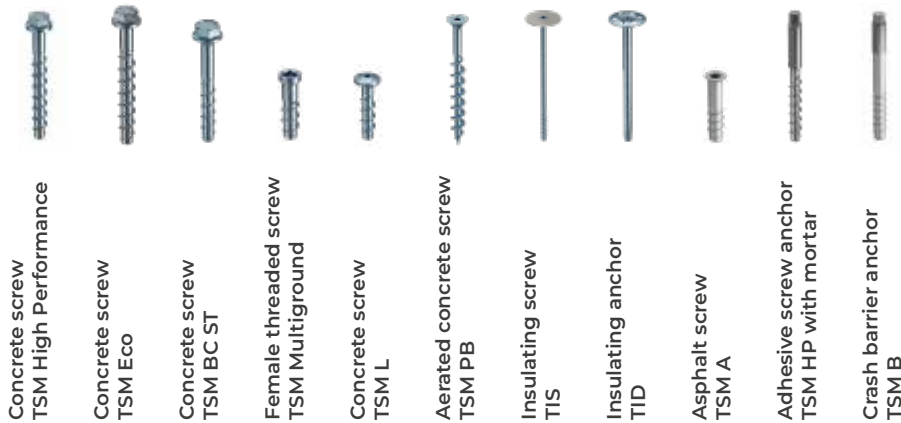

Technical data

Substrate

	Concrete screw TSM High Performance	Concrete screw TSM Eco	Concrete screw TSM BC ST	Female threaded screw TSM Multiground	Concrete screw TSM L	Aerated concrete screw TSM PB	Insulating screw TIS	Insulating anchor TID	Asphalt screw TSM A	Adhesive screw anchor TSM HP with mortar	Crash barrier anchor TSM B
Cracked concrete	✓	✓	✓	✓	✓		✓	✓		✓	✓
Uncracked concrete	✓	✓	✓	✓	✓		✓	✓		✓	✓
Single fastening in concrete	✓	✓	✓							✓	✓
Multiple fastening in concrete	✓			✓	✓		✓	✓			
Prestressed concrete hollow core slabs	✓				✓						
Solid brick masonry	✓	○		○			○	○			
Lightweight concrete	✓										
Aerated concrete						○					
Asphalt									○		
Natural stone with dense structure	○	○		○							

Approvals

ETA-Assessment	✓	✓		✓	✓		✓				
General design type approval	✓		✓		✓		✓	✓		✓	✓
Fire resistance	✓	✓		✓	✓		✓	✓		✓	✓
Tunnel fire test	✓										
Earthquake approval	✓	✓		✓							
VdS recognition	✓		✓								
Temporary, reusable fastening	✓										
WHG requirements (Water Resources Act)	✓										

Materials

Steel, zinc plated	✓	✓	✓	✓	✓	○	✓	✓		✓	
Steel, zinc flake coated	✓		✓				✓		○	✓	✓
Steel, hot-dip galvanised											
Stainless steel A2								✓			
Stainless steel A4	✓									✓	

Installation

Suction drill	✓	✓	✓	✓	✓	○	✓	✓	○	✓	✓
Adjustable	✓	✓			○	○	○		○		

TOGE Product Catalogue 2024 / 2025

EDITORIAL

Innovation and quality
in perfection



We proudly present our new product catalogue 2024/2025. TOGE's wide and extensive range of concrete screws and other fastening products once again sets new standards in terms of quality, safety and innovation. With this catalogue, we offer you a comprehensive overview of the latest developments and additions to our product portfolio, which meets the highest demands in the construction industry.

Our wide range and customised coatings

An outstanding feature of TOGE is our wide and extensive range of concrete screws, which offers the right solution for almost every application.

We place particular emphasis on the variety of coatings that can be selected depending on the area of application. Our products are available in up to five different materials that offer specific advantages:

1. Galvanising: optimum protection against corrosion for general indoor applications.

TOGE TSM Multiground

More about the product on pages 49 to 55

2. TOGE ZFC: Offers increased protection for applications that are exposed to light moisture.

3. TOGE ZFC Solid: Specially developed coating for very high corrosion protection, for example for industrial atmospheres.

4. TOGE KORR: Ideal for highly corrosive environments, such as near the coast or in industrial areas (corrosion class CS - high).

5. Stainless steel: maximum corrosion protection for particularly demanding applications, e.g. in the chemical industry, tunnelling or in seawater environments.



**THE
FASTENING
EXPERTS**



SECURE FASTENING SINCE 1964

These different materials ensure that each of our products is optimally adapted to the respective operating conditions and delivers maximum performance.

Independent tests and approvals as a sign of quality

Another distinguishing feature of TOGE is the large number of approvals that characterise our products. Safety and quality are of the utmost importance to us, which is why all safety-relevant products are subjected to extensive testing procedures. These tests are carried out by independent bodies to ensure that our products meet the highest standards.

The test procedures required by various guidelines guarantee that approved products fulfil the areas of application and performance data specified in the approval. Our concrete screws and fastening solutions are equipped with very high-quality approvals - in some cases even with up to five different approvals for a wide range of applications. These approvals are a real sign of quality and emphasise our claim to offer only the best and safest products.

German quality and reliability

As a manufacturer in Germany, it is a matter of course for us to have our products approved by the German Institute for Building Technology (DIBt). The DIBt enjoys an excellent international reputation, and these approvals fit perfectly with our claim to the highest quality and reliability. We continuously invest in new approvals and the further development of our products in order to always be at the cutting edge of technology and fulfil the requirements of our customers.

We are celebrating our birthday!

More about 60 years of TOGE on page 66

Innovations and expansions in the product portfolio

A highlight in our new catalogue is the **TSM High Performance concrete screw**, which now has ETA approval for masonry. This expands the area of application considerably, as this screw is now approved not only for concrete but also for other substrates.

We have added a second product line to our concrete screw range, which comprises a basic range. Thanks to a special production process, we offer our customers an economical solution that is ideal for applications with lower load requirements. This product line also has a high-quality approval and is of course manufactured in Germany.

Another new product is the **TSM Multiground internally threaded screw**, which is approved for multiple fixings in concrete and offers load recommendations for various other substrates. This screw can be screwed into concrete flush with the surface and is a quick, simple and economical solution for ceiling suspensions. It facilitates especially overhead work and increases efficiency and safety efficiency and safety on the construction site.

Future-proof solutions and continuous further development

Two further approvals will be added to the **TSM LT A4 stainless steel concrete screw** by the end of the year. Firstly, this screw will be integrated into the masonry approval and secondly, it will receive approval as a multiple fastening in concrete and prestressed concrete hollow core slabs. ■



TOGE Product Catalogue 2024 / 2025

CONTENTS

Find exactly what
you are looking for

01 TOGE TSM HIGH PERFORMANCE 7 – 32

Product Information	7
Product Details	9
Technical Characteristics	21
Installation Instructions	28

02 TOGE TSM ECO NEW 33 – 40

Product Information	33
Product Details	35
Technical Characteristics	37
Installation Instructions	39

03 TOGE TSM BC ST 41 – 47

Product Information	41
Product Details	43
Technical Characteristics	46
Installation Instructions	47

04 TOGE TSM MULTIGROUND NEW 49 – 55

Product Information	49
Product Details	51
Technical Characteristics	53
Installation Instructions	55

05 TOGE TSM L 57 – 65

Product Information	57
Product Details	59
Technical Characteristics	63
Installation Instructions	65



06 TOGE TSM PB 67 – 72

Product Information	67
Product Details	69
Technical Characteristics	71
Installation Instructions	72

07 TOGE TIS 73 – 85

Product Information	73
Product Details	75
Technical Characteristics	82
Installation Instructions	85

08 TOGE TID 87 – 95

Product Information	87
Product Details	89
Technical Characteristics	94
Installation Instructions	95

09 TOGE TSM A 97 – 104

Product Information	97
Product Details	98
Technical Characteristics	101
Installation Instructions	102

10 TOGE TSM HP Adhesive screw anchor 105 – 115

Product Information	105
Product Details	107
Technical Characteristics	113
Installation Instructions	115

11 TOGE TSM B Crash barrier anchor 117 – 124

Product Information	117
Product Details	119
Technical Characteristics	122
Installation Instructions	124



01 TOGE TSM HIGH PERFORMANCE

TSM HIGH PERFORMANCE

Our all-rounder concrete screw – even for heavy loads



Large variety

Seven different head shapes and up to three different embedment depths for variable load absorption: always perfectly matched to your individual requirements.



Easy and fast installation

The optimized thread enables a fast and easy installation process.



Adjustable & Demountable

If required, the TOGE TSM High Performance can be adjusted up to twice during assembly. After assembly, it can be disassembled again at any time.



High load level

The special thread geometry ensures extreme hold and high loads in concrete – whether tensile or shear loads.



Combinable system

In combination with our composite mortar, the TSM HP has an even higher load level – and can be loaded immediately. Tested impermeability, even to critical substances, enables use even under WHG requirements (only for TSM LT A4).



Particularly near the edge

Small edge distances and spacing allow very closed-edge and closely spaced installation.

Approval

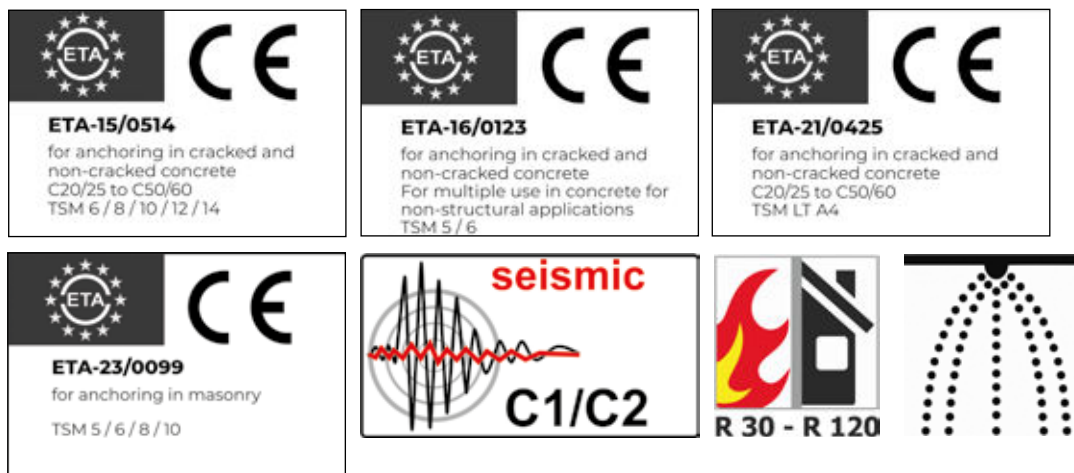

- ✓ European technical assessment ETA-15/0514, single fastening.
- ✓ European technical assessment ETA-16/0123, multiple fastening.
- ✓ European technical assessment ETA-21/0425, TSM LT A4.
- ✓ European technical assessment ETA-23/0099, single fixing in masonry.
- ✓ General design approval Z-21.8-2115 for temporary fastening.
- ✓ General design approval Z-21.1-2074 adhesive concrete screw.

Base Material

- ✓ Approved for concrete strength classes from C20/25 to C50/60.
- ✓ Cracked and non-cracked concrete.
- ✓ Prestressed hollow core slabs (size 6).
- ✓ Solid masonry brick, solid sand-lime brick, perforated sand-lime brick, lightweight concrete.
- ✓ Suitable for natural stone with dense structure.









Scan the QR code and go directly to the product page

For example, to view the approvals in detail you only need one click. Feel free to try it out!

01 TOGE TSM HIGH PERFORMANCE

HEADSHAPES AND MATERIALS

		Steel, zinc plated	Steel, zinc flake-coated	Stainless steel A4
	Hexagon head and pressed on washer	✓	✓	✓
	Countersunk head with multipoint drive	✓		✓
	Panhead with multipoint drive	✓		✓
	Large panhead with multipoint drive	✓		
	Hexagonal drive and metric external thread M8 and M10	✓		
	Metric female thread M8 / M10	✓		✓
	Metric external thread	✓		✓

Application examples

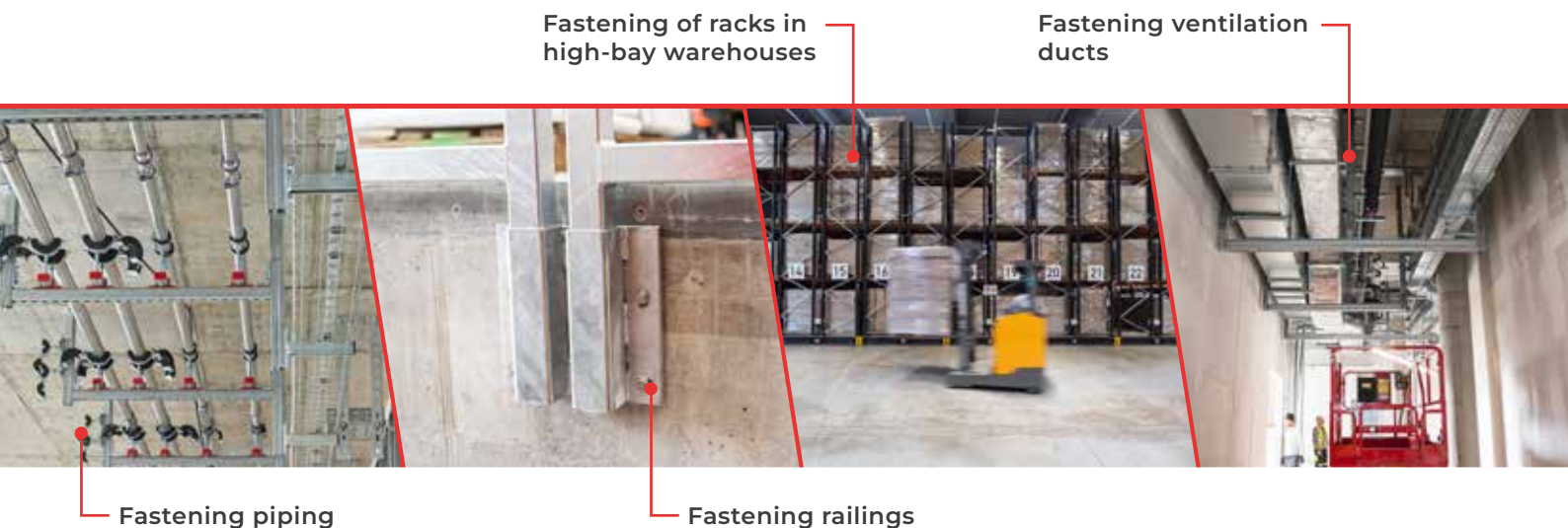

Fastening piping

Fastening railings

Fastening of racks in high-bay warehouses

Fastening ventilation ducts

01 TOGE TSM HIGH PERFORMANCE

STEEL – ZINC PLATED

Version with hexagon head
and pressed on washer



Size	Washer-Ø
5	12,5 mm
6	15,0 mm
8	16,0 mm
10	20,0 mm
12	23,5 mm
14	28,5 mm

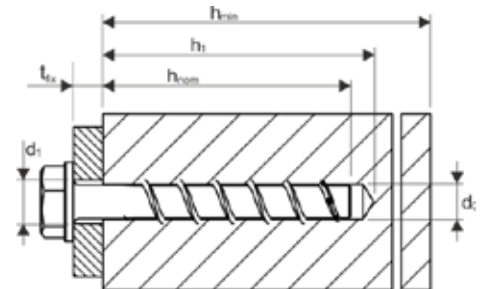

Item nr.	Designation	Depth of drill hole $h_{01}/h_{02}/h_{03}$	Embedment depth of anchor $h_{nom1}/h_{nom2}/h_{nom3}$	Max. thickness of fixture $t_{fix1}/t_{fix2}/t_{fix3}$	Packing Unit
300 005 040	TSM 5x40 SW10	40 mm / - / -	35 mm / - / -	5 mm / - / -	100
300 005 050	TSM 5x50 SW10	40 mm / - / -	35 mm / - / -	15 mm / - / -	100
300 005 060	TSM 5x60 SW10	40 mm / - / -	35 mm / - / -	25 mm / - / -	100
300 005 080	TSM 5x80 SW10	40 mm / - / -	35 mm / - / -	45 mm / - / -	100
300 006 040	TSM 6x40 SW13	40 mm / - / -	35 mm / - / -	5 mm / - / -	100
300 006 050	TSM 6x50 SW13	40 mm / 45 mm / -	35 mm / 40 mm / -	15 mm / 10 mm / -	100
300 006 060	TSM 6x60 SW13	40 mm / 45 mm / 60 mm	35 mm / 40 mm / 55 mm	25 mm / 20 mm / 5 mm	100
300 006 080	TSM 6x80 SW13	40 mm / 45 mm / 60 mm	35 mm / 40 mm / 55 mm	45 mm / 40 mm / 25 mm	100
300 006 100	TSM 6x100 SW13	40 mm / 45 mm / 60 mm	35 mm / 40 mm / 55 mm	65 mm / 60 mm / 45 mm	100
300 008 050	TSM 8x50 SW13	55 mm / - / -	45 mm / - / -	5 mm / - / -	50
300 008 060	TSM 8x60 SW13	55 mm / 65 mm / -	45 mm / 55 mm / -	15 mm / 5 mm / -	50
300 008 070	TSM 8x70 SW13	55 mm / 65 mm / 75 mm	45 mm / 55 mm / 65 mm	25 mm / 15 mm / 5 mm	50
300 008 080	TSM 8x80 SW13	55 mm / 65 mm / 75 mm	45 mm / 55 mm / 65 mm	35 mm / 25 mm / 15 mm	50
300 008 090	TSM 8x90 SW13	55 mm / 65 mm / 75 mm	45 mm / 55 mm / 65 mm	45 mm / 35 mm / 25 mm	50
300 008 100	TSM 8x100 SW13	55 mm / 65 mm / 75 mm	45 mm / 55 mm / 65 mm	55 mm / 45 mm / 35 mm	50
300 008 120	TSM 8x120 SW13	55 mm / 65 mm / 75 mm	45 mm / 55 mm / 65 mm	75 mm / 65 mm / 55 mm	50
300 008 140	TSM 8x140 SW13	55 mm / 65 mm / 75 mm	45 mm / 55 mm / 65 mm	95 mm / 85 mm / 75 mm	50
300 010 060	TSM 10x60 SW 15	65 mm / - / -	55 mm / - / -	5 mm / - / -	50
300 010 070	TSM 10x70 SW15	65 mm / - / -	55 mm / - / -	15 mm / - / -	50
300 010 080	TSM 10x80 SW15	65 mm / 85 mm / -	55 mm / 75 mm / -	25 mm / 5 mm / -	50
300 010 090	TSM 10x90 SW15	65 mm / 85 mm / 95 mm	55 mm / 75 mm / 85 mm	35 mm / 15 mm / 5 mm	50

↪ Type list – continued on page 11

01 TOGE TSM HIGH PERFORMANCE

STEEL – ZINC PLATED

Version with hexagon head and pressed on washer

↪ Continued



Size	Washer-Ø
5	12,5 mm
6	15,0 mm
8	16,0 mm
10	20,0 mm
12	23,5 mm
14	28,5 mm

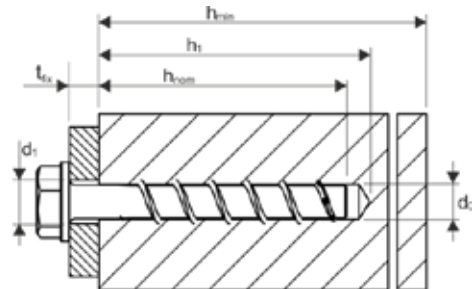

Item nr.	Designation	Depth of drill hole $h_{o1} / h_{o2} / h_{o3}$	Embedment depth of anchor $h_{nom1} / h_{nom2} / h_{nom3}$	Max. thickness of fixture $t_{fix1} / t_{fix2} / t_{fix3}$	Packing Unit
300 010 100	TSM 10x100 SW15	65 mm / 85 mm / 95 mm	55 mm / 75 mm / 85 mm	45 mm / 25 mm / 15 mm	50
300 010 120	TSM 10x120 SW15	65 mm / 85 mm / 95 mm	55 mm / 75 mm / 85 mm	65 mm / 45 mm / 35 mm	50
300 010 140	TSM 10x140 SW15	65 mm / 85 mm / 95 mm	55 mm / 75 mm / 85 mm	85 mm / 65 mm / 55 mm	50
300 010 150	TSM 10x150 SW15	65 mm / 85 mm / 95 mm	55 mm / 75 mm / 85 mm	95 mm / 75 mm / 65 mm	50
300 010 160	TSM 10x160 SW15	65 mm / 85 mm / 95 mm	55 mm / 75 mm / 85 mm	105 mm / 85 mm / 75 mm	50
300 010 180*	TSM 10x180 SW15	65 mm / 85 mm / 95 mm	55 mm / 75 mm / 85 mm	125 mm / 105 mm / 95 mm	25
300 010 200*	TSM 10x200 SW15	65 mm / 85 mm / 95 mm	55 mm / 75 mm / 85 mm	145 mm / 125 mm / 115 mm	25
300 010 240*	TSM 10x240 SW15	65 mm / 85 mm / 95 mm	55 mm / 75 mm / 85 mm	185 mm / 165 mm / 155 mm	25
300 010 280*	TSM 10x280 SW15	65 mm / 85 mm / 95 mm	55 mm / 75 mm / 85 mm	225 mm / 205 mm / 195 mm	25
300 010 320*	TSM 10x320 SW15	65 mm / 85 mm / 95 mm	55 mm / 75 mm / 85 mm	265 mm / 245 mm / 235 mm	25
300 010 360*	TSM 10x360 SW15	65 mm / 85 mm / 95 mm	55 mm / 75 mm / 85 mm	305 mm / 285 mm / 275 mm	25
300 010 400*	TSM 10x400 SW15	65 mm / 85 mm / 95 mm	55 mm / 75 mm / 85 mm	345 mm / 325 mm / 315 mm	25
300 012 080	TSM 12x80 SW17	75 mm / - / -	65 mm / - / -	15 mm / - / -	25
300 012 110	TSM 12x110 SW17	75 mm / 95 mm / 110 mm	65 mm / 85 mm / 100 mm	45 mm / 25 mm / 10 mm	25
300 012 130	TSM 12x130 SW17	75 mm / 95 mm / 110 mm	65 mm / 85 mm / 100 mm	65 mm / 45 mm / 30 mm	25
300 012 150	TSM 12x150 SW17	75 mm / 95 mm / 110 mm	65 mm / 85 mm / 100 mm	85 mm / 65 mm / 50 mm	25
300 014 080	TSM 14x80 SW21	85 mm / - / -	75 mm / - / -	5 mm / - / -	25
300 014 110	TSM 14x110 SW21	85 mm / 110 mm / -	75 mm / 100 mm / -	35 mm / 10 mm / -	25
300 014 130	TSM 14x130 SW21	85 mm / 110 mm / 125 mm	75 mm / 100 mm / 115 mm	55 mm / 30 mm / 15 mm	25
300 014 150	TSM 14x150 SW21	85 mm / 110 mm / 125 mm	75 mm / 100 mm / 115 mm	75 mm / 50 mm / 35 mm	25

* Washer according to DIN 440, galvanised steel, included in delivery.

01 TOGE TSM HIGH PERFORMANCE

STEEL – ZINC PLATED

Version with countersunk head
with multipoint drive



Size

5
6
8
10

Head-Ø

12,0 mm
13,0 mm
19,5 mm
21,5 mm

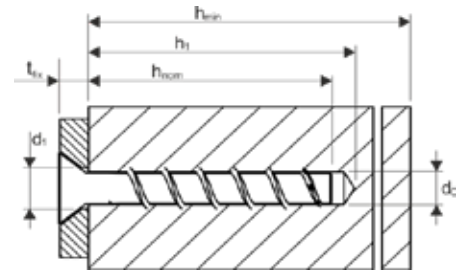

Item nr.	Designation	Depth of drill hole $h_{01} / h_{02} / h_{03}$	Embedment depth of anchor $h_{nom1} / h_{nom2} / h_{nom3}$	Max. thickness of fixture $t_{fix1} / t_{fix2} / t_{fix3}$	Packing Unit
311 005 040	TSM 5x40 C VZ25	40 mm / - / -	35 mm / - / -	5 mm / - / -	100
311 005 050	TSM 5x50 C VZ25	40 mm / - / -	35 mm / - / -	15 mm / - / -	100
311 005 060	TSM 5x60 C VZ25	40 mm / - / -	35 mm / - / -	25 mm / - / -	100
311 006 040	TSM 6x40 C VZ30	40 mm / - / -	35 mm / - / -	5 mm / - / -	100
311 006 050	TSM 6x50 C VZ30	40 mm / 45 mm / -	35 mm / 40 mm / -	15 mm / 10 mm / -	100
311 006 060	TSM 6x60 C VZ30	40 mm / 45 mm / 60 mm	35 mm / 40 mm / 55 mm	25 mm / 20 mm / 5 mm	100
311 006 080	TSM 6x80 C VZ30	40 mm / 45 mm / 60 mm	35 mm / 40 mm / 55 mm	45 mm / 40 mm / 25 mm	100
311 006 100	TSM 6x100 C VZ30	40 mm / 45 mm / 60 mm	35 mm / 40 mm / 55 mm	65 mm / 60 mm / 45 mm	100
311 006 120	TSM 6x120 C VZ30	40 mm / 45 mm / 60 mm	35 mm / 40 mm / 55 mm	85 mm / 80 mm / 65 mm	100
311 006 140	TSM 6x140 C VZ30	40 mm / 45 mm / 60 mm	35 mm / 40 mm / 55 mm	105 mm / 100 mm / 85 mm	100
311 008 080	TSM 8x80 C VZ40	55 mm / 65 mm / 75 mm	45 mm / 55 mm / 65 mm	35 mm / 25 mm / 15 mm	50
311 008 100	TSM 8x100 C VZ40	55 mm / 65 mm / 75 mm	45 mm / 55 mm / 65 mm	55 mm / 45 mm / 35 mm	50
311 008 120	TSM 8x120 C VZ40	55 mm / 65 mm / 75 mm	45 mm / 55 mm / 65 mm	75 mm / 65 mm / 55 mm	50
311 010 090	TSM 10x90 C VZ50	65 mm / 85 mm / 95 mm	55 mm / 75 mm / 85 mm	35 mm / 15 mm / 5 mm	50
311 010 100	TSM 10x100 C VZ50	65 mm / 85 mm / 95 mm	55 mm / 75 mm / 85 mm	45 mm / 25 mm / 15 mm	50
311 010 120	TSM 10x120 C VZ50	65 mm / 85 mm / 95 mm	55 mm / 75 mm / 85 mm	65 mm / 45 mm / 35 mm	50

01 TOGE TSM HIGH PERFORMANCE

STEEL – ZINC PLATED

Version with panhead and multipoint drive



Size
5
6

Head-Ø
14,0 mm
14,5 mm

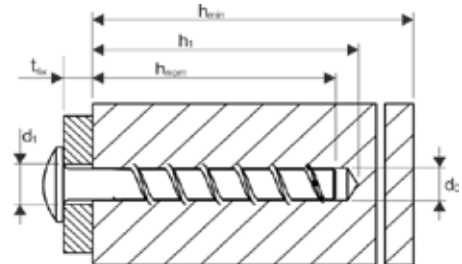

Item nr.	Designation	Depth of drill hole $h_{01} / h_{02} / h_{03}$	Embedment depth of anchor $h_{nom1} / h_{nom2} / h_{nom3}$	Max. thickness of fixture $t_{fix1} / t_{fix2} / t_{fix3}$	Packing Unit
322 005 040	TSM 5x40 P VZ30	40 mm / - / -	35 mm / - / -	5 mm / - / -	100
322 005 050	TSM 5x50 P VZ30	40 mm / - / -	35 mm / - / -	15 mm / - / -	100
322 005 060	TSM 5x60 P VZ30	40 mm / - / -	35 mm / - / -	25 mm / - / -	100
322 006 040	TSM 6x40 P VZ30	40 mm / - / -	35 mm / - / -	5 mm / - / -	100
322 006 050	TSM 6x50 P VZ30	40 mm / 45 mm / -	35 mm / 40 mm / -	15 mm / 10 mm / -	100
322 006 060	TSM 6x60 P VZ30	40 mm / 45 mm / 60 mm	35 mm / 40 mm / 55 mm	25 mm / 20 mm / 5 mm	100
322 006 080	TSM 6x80 P VZ30	40 mm / 45 mm / 60 mm	35 mm / 40 mm / 55 mm	45 mm / 40 mm / 25 mm	100
322 006 100	TSM 6x100 P VZ30	40 mm / 45 mm / 60 mm	35 mm / 40 mm / 55 mm	65 mm / 60 mm / 45 mm	100

Version with large panhead and multipoint drive



Size
6

Head-Ø
18,0 mm

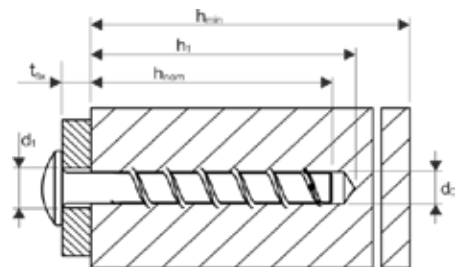

Item nr.	Designation	Depth of drill hole $h_{01} / h_{02} / h_{03}$	Embedment depth of anchor $h_{nom1} / h_{nom2} / h_{nom3}$	Max. thickness of fixture $t_{fix1} / t_{fix2} / t_{fix3}$	Packing Unit
333 006 040	TSM 6x40 LP VZ30	40mm / - / -	35mm / - / -	5mm / - / -	100
333 006 050	TSM 6x50 LP VZ30	40mm / 45mm / 40mm	35mm / 40mm / 55mm	15mm / 10mm / 5mm	100
333 006 060	TSM 6x60 LP VZ30	40mm / 45mm / 60mm	35mm / 40mm / 55mm	25mm / 20mm / 5mm	100

01 TOGE TSM HIGH PERFORMANCE

STEEL – ZINC PLATED

Version with hexagonal drive and metric external thread M8

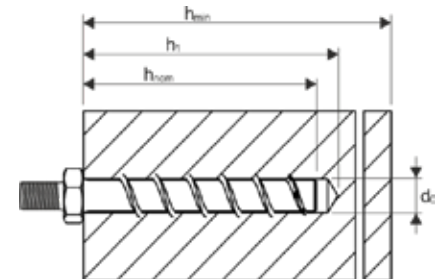

Item nr.	Designation	Depth of drill hole $h_{01} / h_{02} / h_{03}$	Embedment depth of anchor $h_{nom1} / h_{nom2} / h_{nom3}$	Max. thickness of fixture $t_{fix1} / t_{fix2} / t_{fix3}$	Packing Unit
355 006 035	TSM 6x35 K M8-16 SW10	40mm / - / -	35mm / - / -	- / - / -	100
355 006 055	TSM 6x55 M8-16 SW10	40mm / 45mm / 60mm	35mm / 40mm / 55mm	20mm / 15mm / -	100
355 006 075	TSM 6x75 M8-16 SW10	40mm / 45mm / 60mm	35mm / 40mm / 55mm	40mm / 35mm / 20mm	100
355 006 095	TSM 6x95 M8-16 SW10	40mm / 45mm / 60mm	35mm / 40mm / 55mm	60mm / 55mm / 40mm	100
355 006 135	TSM 6x135 M8-16 SW10	40mm / 45mm / 60mm	35mm / 40mm / 55mm	100mm / 95mm / 80mm	100
355 006 155	TSM 6x155 M8-16 SW10	40mm / 45mm / 60mm	35mm / 40mm / 55mm	120mm / 115mm / 100mm	100
355 006 175	TSM 6x175 M8-16 SW10	40mm / 45mm / 60mm	35mm / 40mm / 55mm	140mm / 135mm / 120mm	100
355 006 195	TSM 6x195 M8-16 SW10	40mm / 45mm / 60mm	35mm / 40mm / 55mm	160mm / 155mm / 140mm	100

Version with hexagonal drive and metric external thread M10



Size
6

Washer-Ø
19,0 mm

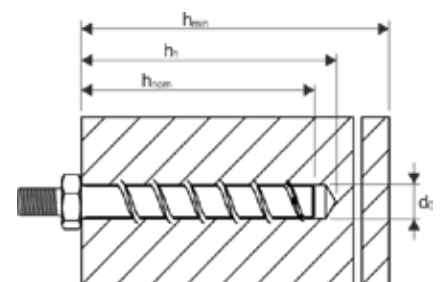

Item nr.	Designation	Depth of drill hole $h_{01} / h_{02} / h_{03}$	Embedment depth of anchor $h_{nom1} / h_{nom2} / h_{nom3}$	Max. thickness of fixture $t_{fix1} / t_{fix2} / t_{fix3}$	Packing Unit
355 206 040	TSM 6x40 M10-20 SW13	40mm / 45mm / -	35mm / 40mm / -	5mm / - / -	100

01 TOGE TSM HIGH PERFORMANCE

STEEL – ZINC PLATED

Version with metric female thread
M8/M10



Size
6

Washer-Ø
25,0 mm

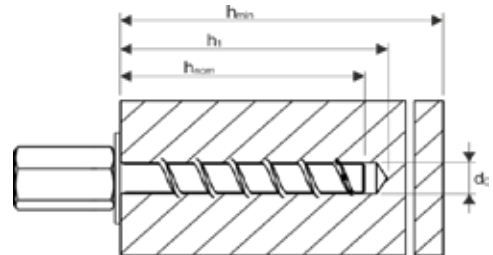

Item nr.	Designation	Depth of drill hole $h_{o1} / h_{o2} / h_{o3}$	Embedment depth of anchor $h_{nom1} / h_{nom2} / h_{nom3}$	Max. thickness of fixture $t_{fix1} / t_{fix2} / t_{fix3}$	Packing Unit
344 006 035	TSM 6x35 K IM 8/10	40mm / - / -	35mm / - / -	- / - / -	50
344 006 055	TSM 6x55 IM 8/10	40mm / 45mm / 65mm	35mm / 40mm / 55mm	20mm / 15mm / -	50

Version with metric
external thread

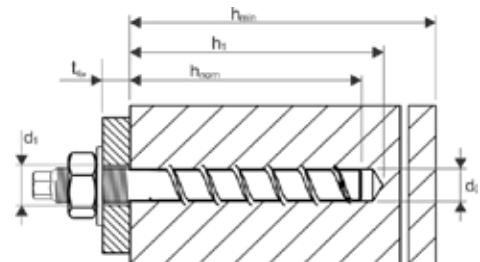

Item nr.	Designation	Depth of drill hole $h_{o1} / h_{o2} / h_{o3}$	Embedment depth of anchor $h_{nom1} / h_{nom2} / h_{nom3}$	Max. thickness of fixture $t_{fix1} / t_{fix2} / t_{fix3}$	Packing Unit
366 008 105	TSM 8x105 M10x30 SW7	55mm / 65mm / 75mm	45mm / 55mm / 65mm	39mm / 29mm / 19mm	50
366 010 120	TSM 10x120 M12x20 SW9	65mm / 85mm / 95mm	55mm / 75mm / 85mm	40mm / 20mm / 10mm	50

01 TOGE TSM HIGH PERFORMANCE

STEEL – ZINC FLAKE-COATED

Version with hexagon head
and pressed on washer



Size

5
6
8
10
12
14

Washer-Ø

12,5 mm
15,0 mm
16,0 mm
20,0 mm
23,5 mm
28,5 mm

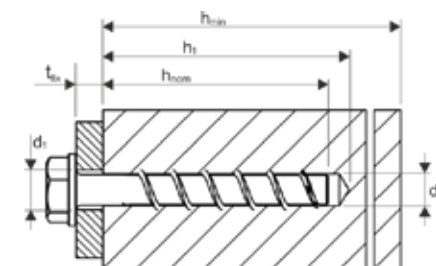

Item nr.	Designation	Depth of drill hole $h_{01} / h_{02} / h_{03}$	Embedment depth of anchor $h_{nom1} / h_{nom2} / h_{nom3}$	Max. thickness of fixture $t_{fix1} / t_{fix2} / t_{fix3}$	Packing Unit
400 005 040	TSM 5x40 SW10 ZFC	40mm / - / -	35mm / - / -	5mm / - / -	100
400 005 050	TSM 5x50 SW10 ZFC	40mm / - / -	35mm / - / -	15mm / - / -	100
400 005 060	TSM 5x60 SW10 ZFC	40mm / - / -	35mm / - / -	25mm / - / -	100
400 005 080	TSM 5x80 SW10 ZFC	40mm / - / -	35mm / - / -	45mm / - / -	100
400 006 040	TSM 6x40 SW13 ZFC	40mm / - / -	35mm / - / -	5mm / - / -	100
400 006 050	TSM 6x50 SW13 ZFC	40mm / 45mm / -	35mm / 40mm / -	15mm / 10mm / -	100
400 006 060	TSM 6x60 SW13 ZFC	40mm / 45mm / 60mm	35mm / 40mm / 55mm	25mm / 20mm / 5mm	100
400 006 080	TSM 6x80 SW13 ZFC	40mm / 45mm / 60mm	35mm / 40mm / 55mm	45mm / 40mm / 25mm	100
400 006 100	TSM 6x100 SW13 ZFC	40mm / 45mm / 60mm	35mm / 40mm / 55mm	65mm / 60mm / 45mm	100
400 008 050	TSM 8x50 SW13 ZFC	55mm / - / -	45mm / - / -	5mm / - / -	50
400 008 060	TSM 8x60 SW13 ZFC	55mm / 65mm / -	45mm / 55mm / -	15mm / 5mm / -	50
400 008 070	TSM 8x70 SW13 ZFC	55mm / 65mm / 75mm	45mm / 55mm / 65mm	25mm / 15mm / 5mm	50
400 008 080	TSM 8x80 SW13 ZFC	55mm / 65mm / 75mm	45mm / 55mm / 65mm	35mm / 25mm / 15mm	50
400 008 090	TSM 8x90 SW13 ZFC	55mm / 65mm / 75mm	45mm / 55mm / 65mm	45mm / 35mm / 25mm	50
400 008 100	TSM 8x100 SW13 ZFC	55mm / 65mm / 75mm	45mm / 55mm / 65mm	55mm / 45mm / 35mm	50
400 008 120	TSM 8x120 SW13 ZFC	55mm / 65mm / 75mm	45mm / 55mm / 65mm	75mm / 65mm / 55mm	50
400 008 140	TSM 8x140 SW13 ZFC	55mm / 65mm / 75mm	45mm / 55mm / 65mm	95mm / 85mm / 75mm	50
400 010 060	TSM 10x60 SW 15 ZFC	65mm / - / -	55mm / - / -	5mm / - / -	50
400 010 070	TSM 10x70 SW15 ZFC	65mm / - / -	55mm / - / -	15mm / - / -	50
400 010 080	TSM 10x80 SW15 ZFC	65mm / 85mm / -	55mm / 75mm / -	25mm / 5mm / -	50
400 010 090	TSM 10x90 SW15 ZFC	65mm / 85mm / 95mm	55mm / 75mm / 85mm	35mm / 15mm / 5mm	50
400 010 100	TSM 10x100 SW15 ZFC	65mm / 85mm / 95mm	55mm / 75mm / 85mm	45mm / 25mm / 15mm	50

↳ Type list – continued on page 17

01 TOGE TSM HIGH PERFORMANCE

**STEEL -
ZINC FLAKE-COATED**

Version with hexagon head
and pressed on washer

↳ Continued



Size	Washer-Ø
5	12,5 mm
6	15,0 mm
8	16,0 mm
10	20,0 mm
12	23,5 mm
14	28,5 mm

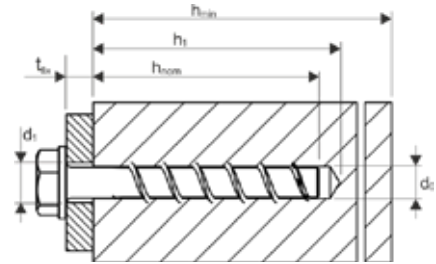

Item nr.	Designation	Depth of drill hole $h_{01} / h_{02} / h_{03}$	Embedment depth of anchor $h_{nom1} / h_{nom2} / h_{nom3}$	Max. thickness of fixture $t_{fix1} / t_{fix2} / t_{fix3}$	Packing Unit
400 010 120	TSM 10x120 SW15 ZFC	65mm / 85mm / 95mm	55mm / 75mm / 85mm	65mm / 45mm / 35mm	50
400 010 140	TSM 10x140 SW15 ZFC	65mm / 85mm / 95mm	55mm / 75mm / 85mm	85mm / 65mm / 55mm	50
400 010 150	TSM 10x150 SW15 ZFC	65mm / 85mm / 95mm	55mm / 75mm / 85mm	95mm / 75mm / 65mm	50
400 010 160	TSM 10x160 SW15 ZFC	65mm / 85mm / 95mm	55mm / 75mm / 85mm	105mm / 85mm / 75mm	50
400 010 180*	TSM 10x180 SW15 ZFC	65mm / 85mm / 95mm	55mm / 75mm / 85mm	125mm / 105mm / 95mm	25
400 010 200*	TSM 10x200 SW15 ZFC	65mm / 85mm / 95mm	55mm / 75mm / 85mm	145mm / 125mm / 115mm	25
400 010 240*	TSM 10x240 SW15 ZFC	65mm / 85mm / 95mm	55mm / 75mm / 85mm	185mm / 165mm / 155mm	25
400 010 280*	TSM 10x280 SW15 ZFC	65mm / 85mm / 95mm	55mm / 75mm / 85mm	225mm / 205mm / 195mm	25
400 010 320*	TSM 10x320 SW15 ZFC	65mm / 85mm / 95mm	55mm / 75mm / 85mm	265mm / 245mm / 235mm	25
400 010 360*	TSM 10x360 SW15 ZFC	65mm / 85mm / 95mm	55mm / 75mm / 85mm	305mm / 285mm / 275mm	25
400 010 400*	TSM 10x400 SW15 ZFC	65mm / 85mm / 95mm	55mm / 75mm / 85mm	345mm / 325mm / 315mm	25
400 012 080	TSM 12x80 SW17 ZFC	75mm / - / -	65mm / - / -	15mm / - / -	25
400 012 110	TSM 12x110 SW17 ZFC	75mm / 95mm / 110mm	65mm / 85mm / 100mm	45mm / 25mm / 10mm	25
400 012 130	TSM 12x130 SW17 ZFC	75mm / 95mm / 110mm	65mm / 85mm / 100mm	65mm / 45mm / 30mm	25
400 012 150	TSM 12x150 SW17 ZFC	75mm / 95mm / 110mm	65mm / 85mm / 100mm	85mm / 65mm / 50mm	25
400 014 080	TSM 14x80 SW21 ZFC	85mm / - / -	75mm / - / -	5mm / - / -	25
400 014 110	TSM 14x110 SW21 ZFC	85mm / 110mm / -	75mm / 100mm / -	35mm / 10mm / -	25
400 014 130	TSM 14x130 SW21 ZFC	85mm / 110mm / 125mm	75mm / 100mm / 115mm	55mm / 30mm / 15mm	25
400 014 150	TSM 14x150 SW21 ZFC	85mm / 110mm / 125mm	75mm / 100mm / 115mm	75mm / 50mm / 35mm	25

Washer according to DIN 440, galvanised steel, included in delivery

01 TOGE TSM HIGH PERFORMANCE

STAINLESS STEEL – LT A4

Version with hexagon head and pressed on washer



Size
6
8
10

Washer-Ø
17,0 mm
16,0 mm
20,0 mm

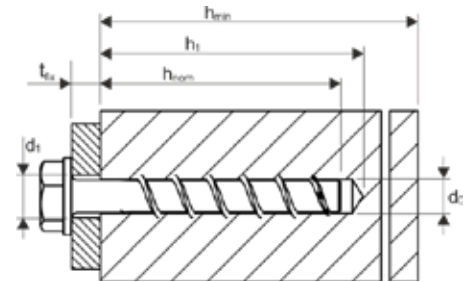

Item nr.	Designation	Depth of drill hole $h_{01} / h_{02} / h_{03}$	Embedment depth of anchor $h_{nom1} / h_{nom2} / h_{nom3}$	Max. thickness of fixture $t_{fix1} / t_{fix2} / t_{fix3}$	Packing Unit
700 006 050	TSM 6x50 SW13 LT A4	40mm / 50mm / -	35mm / 45mm / -	15mm / 5mm / -	100
700 006 060	TSM 6x60 SW13 LT A4	40mm / 50mm / 60mm	35mm / 45mm / 55mm	25mm / 15mm / 5mm	100
700 006 070	TSM 6x70 SW13 LT A4	40mm / 50mm / 60mm	35mm / 45mm / 55mm	35mm / 25mm / 15mm	100
700 008 070	TSM 8x70 SW13 LT A4	55mm / 65mm / 75mm	45mm / 55mm / 65mm	25mm / 15mm / 5mm	50
700 008 080	TSM 8x80 SW13 LT A4	55mm / 65mm / 75mm	45mm / 55mm / 65mm	35mm / 25mm / 15mm	50
700 010 090	TSM 10x90 SW15 LT A4	65mm / 85mm / 95mm	55mm / 75mm / 85mm	35mm / 15mm / 5mm	50
700 010 100	TSM 10x100 SW15 LT A4	65mm / 85mm / 95mm	55mm / 75mm / 85mm	45mm / 25mm / 15mm	50
700 010 120	TSM 10x120 SW15 LT A4	65mm / 85mm / 95mm	55mm / 75mm / 85mm	65mm / 45mm / 35mm	50



**Do you need support?
We will be happy to advise you!**

Call us: +49 911 659 68-43

01 TOGE TSM HIGH PERFORMANCE

STAINLESS STEEL – LT A4

Version with countersunk head with multipoint drive



Size
6
8
10

Head-Ø
13,0 mm
19,5 mm
21,5 mm

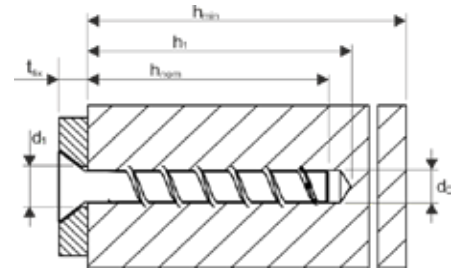

Item nr.	Designation	Depth of drill hole $h_{o1} / h_{o2} / h_{o3}$	Embedment depth of anchor $h_{nom1} / h_{nom2} / h_{nom3}$	Max. thickness of fixture $t_{fix1} / t_{fix2} / t_{fix3}$	Packing Unit
711 006 050	TSM 6x50 C VZ30 LT A4	40mm / 50mm / -	35mm / 45mm / -	15mm / 5mm / -	100
711 006 065	TSM 6x65 C VZ30 LT A4	40mm / 50mm / 60mm	35mm / 45mm / 55mm	30mm / 20mm / 10mm	100
711 006 085	TSM 6x85 C VZ30 LT A4	40mm / 50mm / 60mm	35mm / 45mm / 55mm	50mm / 40mm / 30mm	100
711 006 105	TSM 6x105 C VZ30 LT A4	40mm / 50mm / 60mm	35mm / 45mm / 55mm	70mm / 60mm / 50mm	100
711 008 080	TSM 8x80 C VZ40 LT A4	55mm / 65mm / 75mm	45mm / 55mm / 65mm	35mm / 25mm / 15mm	50
711 008 100	TSM 8x100 C VZ40 LT A4	55mm / 65mm / 75mm	45mm / 55mm / 65mm	55mm / 45mm / 35mm	50
711 008 120	TSM 8x120 C VZ40 LT A4	55mm / 65mm / 75mm	45mm / 55mm / 65mm	75mm / 65mm / 55mm	50
711 010 090	TSM 10x90 C VZ50 LT A4	65mm / 85mm / 95mm	55mm / 75mm / 85mm	35mm / 15mm / 5mm	50
711 010 100	TSM 10x100 C VZ50 LT A4	65mm / 85mm / 95mm	55mm / 75mm / 85mm	45mm / 25mm / 15mm	50
711 010 120	TSM 10x120 C VZ50 LT A4	65mm / 85mm / 95mm	55mm / 75mm / 85mm	65mm / 45mm / 35mm	50

Version with panhead and multipoint drive



Size
6

Head-Ø
15,0 mm

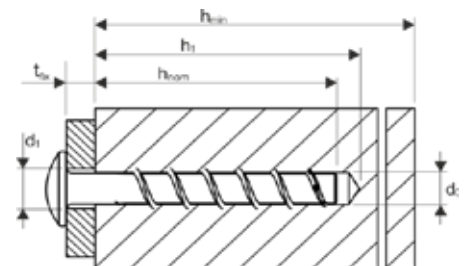

Item nr.	Designation	Depth of drill hole $h_{o1} / h_{o2} / h_{o3}$	Embedment depth of anchor $h_{nom1} / h_{nom2} / h_{nom3}$	Max. thickness of fixture $t_{fix1} / t_{fix2} / t_{fix3}$	Packing Unit
722 006 050	TSM 6x50 P VZ30 LT A4	40mm / 50mm / -	35mm / 45mm / -	15mm / 5mm / -	100
722 006 060	TSM 6x60 P VZ30 LT A4	40mm / 50mm / 60mm	35mm / 45mm / 55mm	25mm / 15mm / 5mm	100
722 006 080	TSM 6x80 P VZ30 LT A4	40mm / 50mm / 60mm	35mm / 45mm / 55mm	45mm / 35mm / 25mm	100
722 006 100	TSM 6x100 P VZ30 LT A4	40mm / 50mm / 60mm	35mm / 45mm / 55mm	65mm / 55mm / 45mm	100

01 TOGE TSM HIGH PERFORMANCE

STAINLESS STEEL – LT A4

Version with metric female thread
M8/M10



Size
6

Washer-Ø
25,0 mm

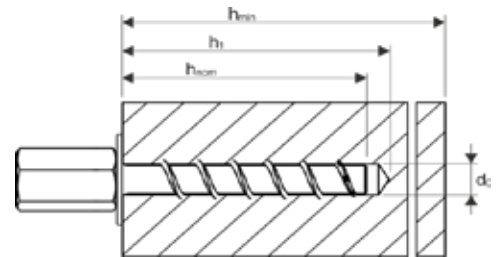

Item nr.	Designation	Depth of drill hole $h_{01} / h_{02} / h_{03}$	Embedment depth of anchor $h_{nom1} / h_{nom2} / h_{nom3}$	Max. thickness of fixture $t_{fix1} / t_{fix2} / t_{fix3}$	Packing Unit
744 006 045	TSM 6x45 K IM 8/10 LT A4	50 mm / - / -	45 mm / - / -	- / - / -	50

Version with
metric external thread 1)

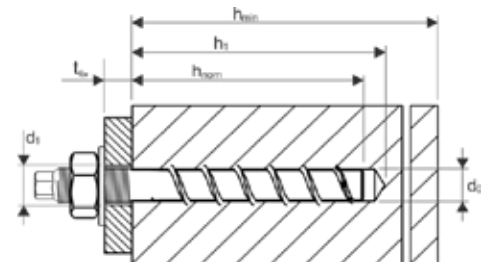

Item nr.	Designation	Depth of drill hole $h_{01} / h_{02} / h_{03}$	Embedment depth of anchor $h_{nom1} / h_{nom2} / h_{nom3}$	Max. thickness of fixture $t_{fix1} / t_{fix2} / t_{fix3}$	Packing Unit
866 008 105	TSM 8x105 M10x30 SW7 A4	55mm / 65mm / 75mm	45mm / 55mm / 65mm	39mm / 29mm / 19mm	50
866 010 140	TSM 10x140 M12x35 SW9 A4	65mm / 85mm / 95mm	55mm / 75mm / 85mm	59mm / 39mm / 29mm	50
866 010 160	TSM 10x160 M12x55 SW9 A4	65mm / 85mm / 95mm	55mm / 75mm / 85mm	79mm / 59mm / 49mm	50

¹⁾ Technical data for this design can be found in the tables for steel zinc plated.

01 TOGE TSM HIGH PERFORMANCE

TECHNICAL CHARACTERISTICS

Single fastening without fire exposure, Steel

Screw size TSM high performance			TSM 6		TSM 8			TSM 10			TSM 12			TSM 14		
Nominal embedment depth	h _{nom}	[mm]	h _{nom1}	h _{nom2}	h _{nom1}	h _{nom2}	h _{nom3}	h _{nom1}	h _{nom2}	h _{nom3}	h _{nom1}	h _{nom2}	h _{nom3}	h _{nom1}	h _{nom2}	h _{nom3}
			40	55	45	55	65	55	75	85	65	85	100	75	100	115
Nominal diameter of drill bit	d ₀	[mm]	6		8			10			12			14		
Depth of drill hole	h _{0 min}	[mm]	45	60	55	65	75	65	85	95	75	95	110	85	110	125
Effective anchorage depth	h _{ef}	[mm]	31	44	35	43	52	43	60	68	50	67	80	58	79	92
Diameter of clearance hole in the fixture	d _{i max}	[mm]	8		12			14			16			18		
Approved tension load in cracked concrete ^{1),2)}	N _{zul}	[kN]	1,0	1,9	2,4	4,3	5,7	4,3	7,6	9,2	5,7	9,0	11,7	7,2	11,5	14,5
Approved shear load in cracked concrete ^{1),2)}	V _{zul}	[kN]	2,8	4,0	3,4	4,6	6,2	4,6	15,2	18,4	5,8	18,0	23,5	7,2	23,0	28,9
Approved tension load in non-cracked concrete ^{1),2)}	N _{zul}	[kN]	1,9	4,3	3,6	5,7	7,6	5,7	9,5	12,4	7,6	12,9	16,8	10,4	16,5	20,7
Approved shear load in non-cracked concrete ^{1),2)}	V _{zul}	[kN]	4,0	4,0	4,9	6,6	8,8	6,6	19,4	19,4	8,3	24,0	24,0	10,4	32,0	32,0
Permissible bending moment	M _{zul}	[kN]	6,2		14,9			32,0			64,6			105,7		
Minimum edge distance	C _{min}	[mm]	40	40	50		50			50	70	50	70	70		
Minimum spacing	S _{min}	[mm]	40	40	50		50			50	70	50	70	70		
Minimum Basements thickness	h _{min}	[mm]	100		100			100	130		120	130	150	130	150	170
Installation torque (with metric connection thread)	T _{inst}	[Nm]	10		20			40			60			80		
Maximum torque (with impact screw driver)		[Nm]	160		300			400			650			650		
ETA Seismic C1	C1		Yes		x	Yes	Yes	x	Yes	x	Yes	x	Yes	x	Yes	
ETA Seismic C2	C2		x	x	Yes	x	Yes	x	Yes	x	Yes	x	Yes	x	Yes	

¹⁾ To determine the permissible load, the partial safety factor from the approval $\gamma_M = 1.0$ was taken into account on the resistance side and on the action side a partial safety factor $\gamma_F = 1.4$ was taken into account.

²⁾ The specified values apply regardless of center and edge distances.

01 TOGE TSM HIGH PERFORMANCE

TECHNICAL CHARACTERISTICS

Single fastening under fire exposure, Steel

Screw size TSM high performance				TSM 6		TSM 8			TSM 10			TSM 12			TSM 14		
Nominal embedment depth		h_{nom}	[mm]	h_{nom1}	h_{nom2}	h_{nom1}	h_{nom2}	h_{nom3}	h_{nom1}	h_{nom2}	h_{nom3}	h_{nom1}	h_{nom2}	h_{nom3}	h_{nom1}	h_{nom2}	h_{nom3}
				40	55	45	55	65	55	75	85	65	85	100	75	100	115
Permissible load under tensile and shear use ($F_{zul,fi} = N_{zul,fi} = V_{zul,fi}$)																	
Fire resistance class																	
R 30	Approved load	$F_{zul,fi 30}$	[kN]	0,5	0,9	1,2	2,1	2,4	2,1	4,0	4,4	3,0	4,7	6,2	3,8	6,0	7,6
R 60		$F_{zul,fi 60}$	[kN]	0,5	0,8	1,2	1,7	1,7	2,1	3,3		3,0	4,7	5,8	3,8	6,0	7,6
R 90		$F_{zul,fi 90}$	[kN]	0,5	0,6	1,1			2,1	2,3		3,0	4,2		3,8	5,9	
R 120		$F_{zul,fi 120}$	[kN]	0,4		0,7			1,7			2,4	3,4		3,0	4,8	
R 30		$M_{zul,fi 30}$	[Nm]	0,7		2,4			5,9			12,3			20,4		
R 60		$M_{zul,fi 60}$	[Nm]	0,6		1,8			4,5			9,7			15,9		
R 90		$M_{zul,fi 90}$	[Nm]	0,5		1,2			3,0			7,0			11,6		
R 120		$M_{zul,fi 120}$	[Nm]	0,3		0,9			2,3			5,7			9,4		
Edge distance																	
R 30 to R 120		$C_{cr,fi}$	[mm]	$2 \times h_{ef}$													
The edge distance must be at least 300 mm if the fire load attacks from more than one side.																	
Spacing																	
R 30 to R 120		$S_{cr,fi}$	[mm]	$4 \times h_{ef}$													
Concrete pry-out failure																	
R 30 to R 120		k	[-]	1,0	1,0			1,0	2,0	1,0	2,0	1,0	2,0	1,0	2,0		
In wet concrete, the embedment depth must be increased by at least 30 mm.																	

01 TOGE TSM HIGH PERFORMANCE

TECHNICAL CHARACTERISTICS

Single fastening without fire exposure, stainless steel A4

Screw size TSM high performance LT A4			TSM 6			TSM 8			TSM 10		
Nominal embedment depth	h _{nom}	[mm]	h _{nom1}	h _{nom2}	h _{nom3}	h _{nom1}	h _{nom2}	h _{nom3}	h _{nom1}	h _{nom2}	h _{nom3}
			35 ³⁾	45	55	45	55	65	55	75	85
Nominal diameter of drill bit	d _o	[mm]	6			8			10		
Depth of drill hole	h _o min	[mm]	40	50	60	55	65	75	65	85	95
Effective anchorage depth	h _{ef}	[mm]	25	34	42	32	41	49	40	57	65
Diameter of clearance hole in the fixture	d _f max	[mm]	8			12			14		
Approved tension load in cracked concrete ^{1) 2)}	N _{zul}	[kN]	1,2	0,7	1,4	1,4	2,6	3,8	2,9	6,2	8,1
Approved shear load in cracked concrete ^{1) 2)}	V _{zul}	[kN]	2,1	4,0	4,0	6,2	7,7	9,7	10,4	17,6	19,4
Approved tension load in non-cracked concrete ^{1) 2)}	N _{zul}	[kN]	1,7	1,9	4,1	4,2	5,7	8,0	5,2	9,1	11,9
Approved shear load in non-cracked concrete ^{1) 2)}	V _{zul}	[kN]	2,9	4,0	4,0	7,7	7,7	9,7	12,9	19,4	19,4
Persmissible bending moment	M _{zul}	[kN]	6,2			14,9			32,0		
Minimum egde distance	C _{min}	[mm]	35			35			40		
Minimum spacing	S _{min}	[mm]	35			35			40		
Minimum Basements thickness	h _{min}	[mm]	80	100		80	100	120	100	130	
Installation torque (with metric connection thread)	T _{inst}	[Nm]	10			20			40		
Maximum torque (with impact screw driver)		[Nm]	160			300			450		
ETA Seismic C1	C1		x	Yes		Yes	x	Yes	Yes	x	Yes

¹⁾ For the determination of the approved loads, the partial safety factor from the approval γ_M = 1,0 was taken into account for material resistance and a partial safety factor γ_F = 1,4 for load actions.

²⁾ These values apply without influence of the spacing and edge distances.

³⁾ Only for multiple use under dry conditions.

01 TOGE TSM HIGH PERFORMANCE

TECHNICAL CHARACTERISTICS

Single fastening under fire exposure, stainless steel A4

Screw size TSM high performance LT A4		TSM 6			TSM 8			TSM 10				
Nominal embedment depth		h_{nom}	[mm]									
		h_{nom1}	h_{nom2}	h_{nom3}	h_{nom1}	h_{nom2}	h_{nom3}	h_{nom1}	h_{nom2}	h_{nom3}		
		35 ³⁾	45	55	45	55	65	55	75	85		
Permissible load under tensile and shear use ($F_{zul,fi} = N_{zul,fi} = V_{zul,fi}$)												
Fire resistance class												
R 30	Approved load	$F_{zul,fi 30}$	[kN]	0,5	0,4	0,8	0,8	1,4	2,0	1,5	3,3	4,3
R 60		$F_{zul,fi 60}$	[kN]	0,5	0,4	0,8	0,8	1,4	1,7	1,5	3,3	
R 90		$F_{zul,fi 90}$	[kN]	0,5	0,4	0,6	0,8	1,1		1,5	2,3	
R 120		$F_{zul,fi 120}$	[kN]	0,4	0,3	0,4	0,6	0,7		1,2	1,7	
R 30		$M_{zul,fi 30}$	[Nm]	0,7			2,4			5,9		
R 60		$M_{zul,fi 60}$	[Nm]	0,6			1,8			4,5		
R 90		$M_{zul,fi 90}$	[Nm]	0,5			1,2			3,0		
R 120		$M_{zul,fi 120}$	[Nm]	0,3			0,9			2,3		
Edge distance												
R 30 to R 120		$C_{cr,fi}$	[mm]	2 x h_{ef}								
The edge distance must be at least 300 mm if the fire load attacks from more than one side.												
Spacing												
R 30 to R 120	$S_{cr,fi}$	[mm]	4 x h_{ef}									
Concrete pry-out failure												
R 30 to R 120	k	[-]	1,0	1,6	2,1	2,8	2,5					
In wet concrete, the embedment depth must be increased by at least 30 mm.												

³⁾ Only for multiple use under dry conditions.

01 TOGE TSM HIGH PERFORMANCE

TECHNICAL CHARACTERISTICS

Multiple fastening without fire exposure, Steel

Screw size TSM high performance		TSM 5	TSM 6	
Nominal embedment depth	h_{nom} [mm]	35	35	55
Nominal diameter of drill bit	d_0 [mm]	5	6	
Depth of drill hole	h_0 min [mm]	40	40	60
Effective anchorage depth	h_{ef} [mm]	27	27	44
Diameter of clearance hole in the fixture	d_f max [mm]	7	8	
Approved tension load in cracked concrete ¹⁾²⁾	N_{zul} [kN]	0,6	1,4	3,6
Approved shear load in cracked concrete ¹⁾²⁾	V_{zul} [kN]	1,9	2,3	4,8
Approved tension load in non-cracked concrete ¹⁾²⁾	N_{zul} [kN]	0,6	1,4	3,6
Approved shear load in non-cracked concrete ¹⁾²⁾	V_{zul} [kN]	2,5	3,3	4,0
Minimum edge distance	c_{min} [mm]	35	35	40
Minimum spacing	s_{min} [mm]	35	35	40
Minimum Basements thickness	h_{min} [mm]	80	80	100
Installation torque (with metric connection thread)	T_{inst} [Nm]	8	10	
Maximum torque (with impact screw driver)	[Nm]	110	160	

¹⁾ For the determination of the approved loads, the partial safety factor from the approval $\gamma_M=1,0$ was taken into account for material resistance and a partial safety factor $\gamma_F=1,4$ for load actions.

²⁾ These values apply without influence of the spacing and edge distances.

01 TOGE TSM HIGH PERFORMANCE

TECHNICAL CHARACTERISTICS

Multiple fastening under fire exposure, Steel

Screw size TSM high performance			TSM 5	TSM 6		
Nominal embedment depth		h_{nom}	[mm]	h_{nom1}	h_{nom1}	h_{nom2}
				35	35	55
Permissible load under tensile and shear use ($F_{zul,fi} = N_{zul,fi} = V_{zul,fi}$)						
Fire resistance class						
R 30	Approved load	$F_{zul,fi 30}$	[kN]	0,4	0,8	0,9
R 60		$F_{zul,fi 60}$	[kN]	0,4	0,8	
R 90		$F_{zul,fi 90}$	[kN]	0,4	0,6	
R 120		$F_{zul,fi 120}$	[kN]	0,3	0,4	
R 30		$M_{zul,fi 30}$	[Nm]	0,5	0,7	
R 60		$M_{zul,fi 60}$	[Nm]	0,4	0,6	
R 90		$M_{zul,fi 90}$	[Nm]	0,2	0,5	
R 120		$M_{zul,fi 120}$	[Nm]	0,2	0,3	
Edge distance						
R 30 to R 120		$C_{cr,fi}$	[mm]	$2 \times h_{ef}$		
The edge distance must be at least 300 mm if the fire load attacks from more than one side.						
Spacing						
R 30 to R 120		$S_{cr,fi}$	[mm]	$4 \times h_{ef}$		
Concrete pry-out failure						
R 30 to R 120		k	[-]	1,0		
In wet concrete, the embedment depth must be increased by at least 30 mm.						

01 TOGE TSM HIGH PERFORMANCE

TECHNICAL CHARACTERISTICS

Multiple fastening in prestressed hollow core slabs without fire exposure, steel

Screw size TSM high performance		TSM 6		
Bottom flange thickness	d_b [mm]	≥ 25	≥ 30	≥ 35
Nominal diameter of drill bit	d_o [mm]	6		
Depth of drill hole	h_o min [mm]	30	35	40
Diameter of clearance hole in the fixture	d_i max [mm]	8		
Approved tension load ¹⁾	F_{zul} [kN]	0,5	1,0	1,4
Minimum edge distance	C_{min} [mm]	100		
Minimum spacing	S_{min} [mm]	100		
Minimum distance between anchor groups	a_{min} [mm]	100		
Core distance	l_c min [mm]	100		
Prestressing steel distance	l_p min [mm]	100		
Distance between anchor position & prestressing steel	a_p min [mm]	50		
Hollow core width (w)	(w/e) max [mm]	4,2		
Bridge width (e)		4,2		
Installation torque (with metric connection thread)	T_{inst} [Nm]	10		
Maximum torque (with impact screw driver)		160		

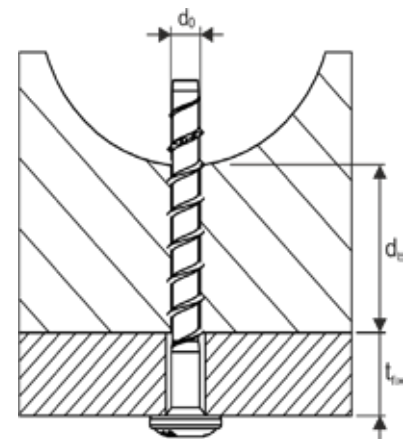

¹⁾ For the determination of the approved loads, the partial safety factor from the approval $\gamma_M = 1,0$ was taken into account for material resistance and a partial safety factor $\gamma_F = 1,4$ for load actions.

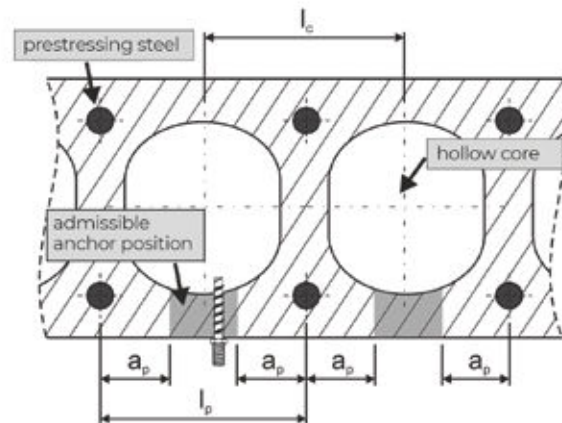
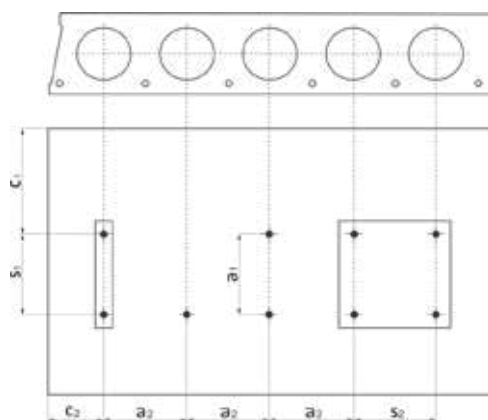

C_1, C_2 = Edge distance
 S_1, S_2 = Spacing
 a_1, a_2 = Distance between anchor groups

l_c = Core distance
 l_p = Prestressing steel distance
 a_p = Distance between anchor position and prestressing steel

01 TOGE TSM HIGH PERFORMANCE

INSTALLATION INSTRUCTIONS

Installation instructions for concrete

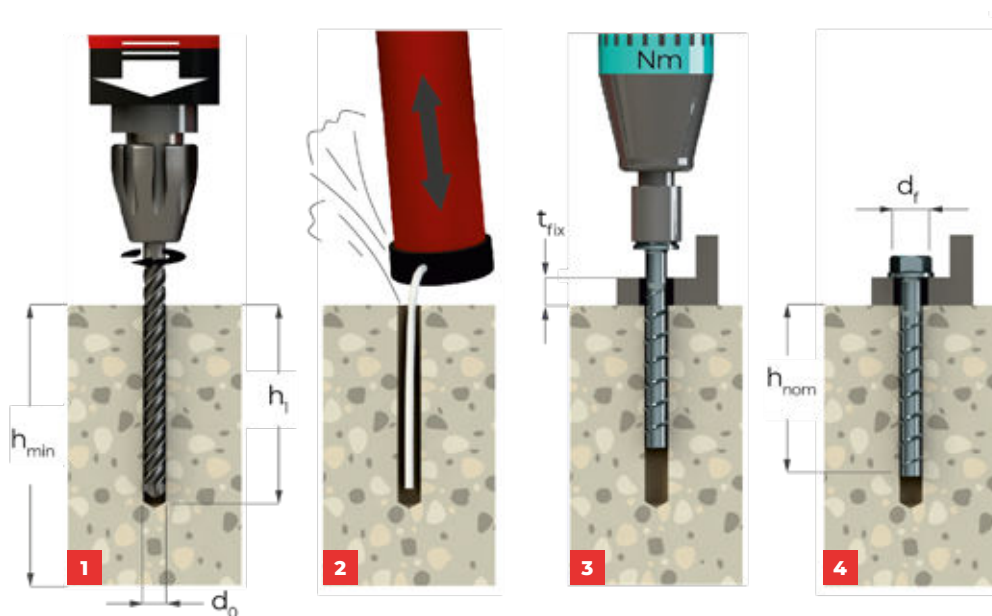

- 1** Create borehole.
- 2** Clean the borehole thoroughly.
- 3** Screw in concrete screw TOGE TSM High Performance.
- 4** The screw head must rest completely on the attachment.



Leading the way in concrete screw technology

We have been dedicated to the development of concrete screws for over 30 years, making us one of the pioneers in this field.

SIDE NOTE

01 TOGE TSM HIGH PERFORMANCE

INSTALLATION INSTRUCTIONS

Installation instructions
with adjustment for sizes 6 to 14

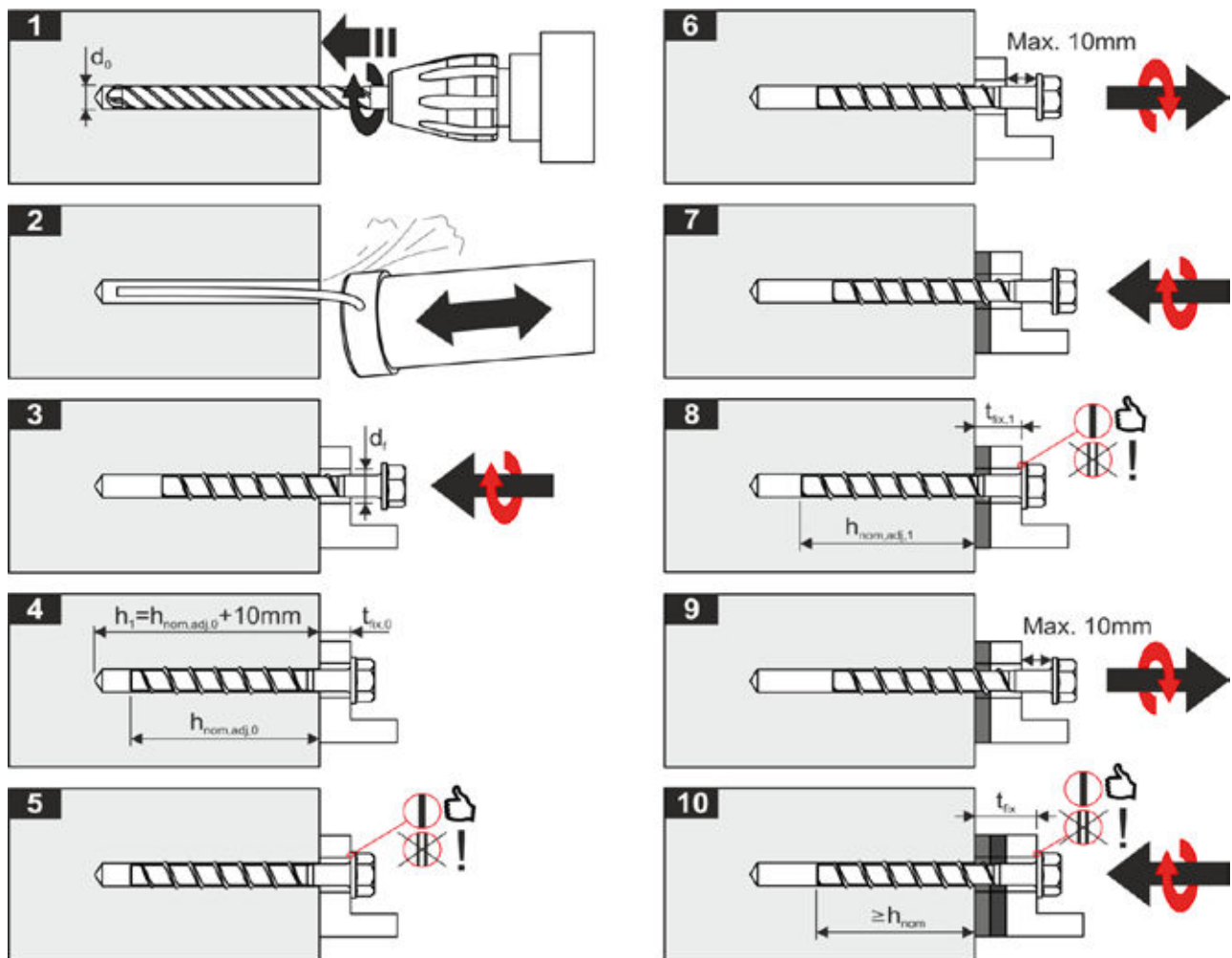

⚠ Important – please note during adjustment:

1. The anchor may be adjusted maximum two times while the anchor may turn back at most 10 mm.
2. The total allowed thickness of shims added during the adjustment process is 10 mm.
3. The final embedment depth after adjustment process must be equal or longer than h_{nom} .

01 TOGE TSM HIGH PERFORMANCE

INSTALLATION INSTRUCTIONS

Installation instructions for prestressed hollow core slabs

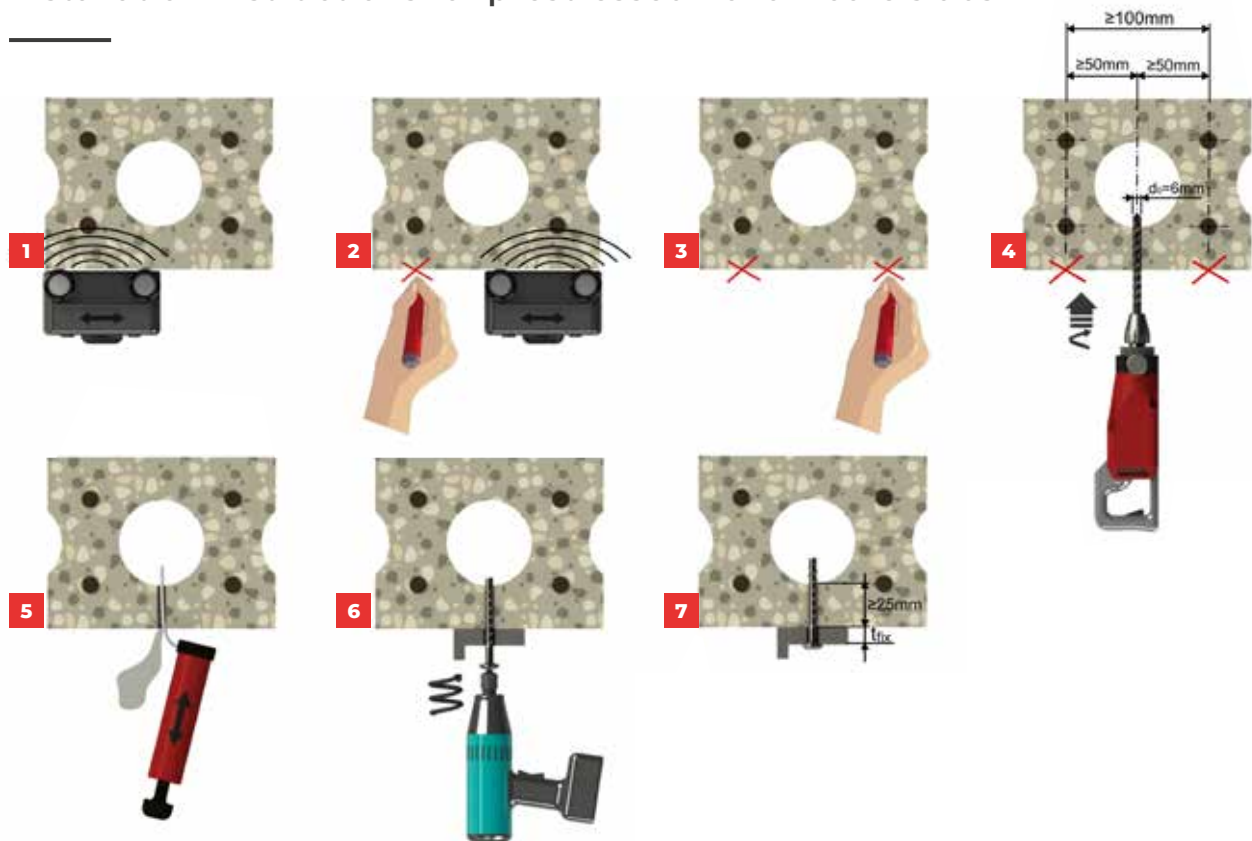

- 1 2 3 Locate prestressing steel with the reinforcement bar detector and mark the location.
- 4 Create hole in the permissible anchoring area.
- 5 Clean hole.
- 6 Screw in concrete screw.
- 7 Screw head must fully contact the fixture.



Unique range of concrete screws

As a specialist in concrete screws, we produce more than 600 different product types in this category.

SIDE NOTE

01 TOGE TSM HIGH PERFORMANCE

INSTALLATION INSTRUCTIONS

Installation instructions für Montage in Mauerwerk

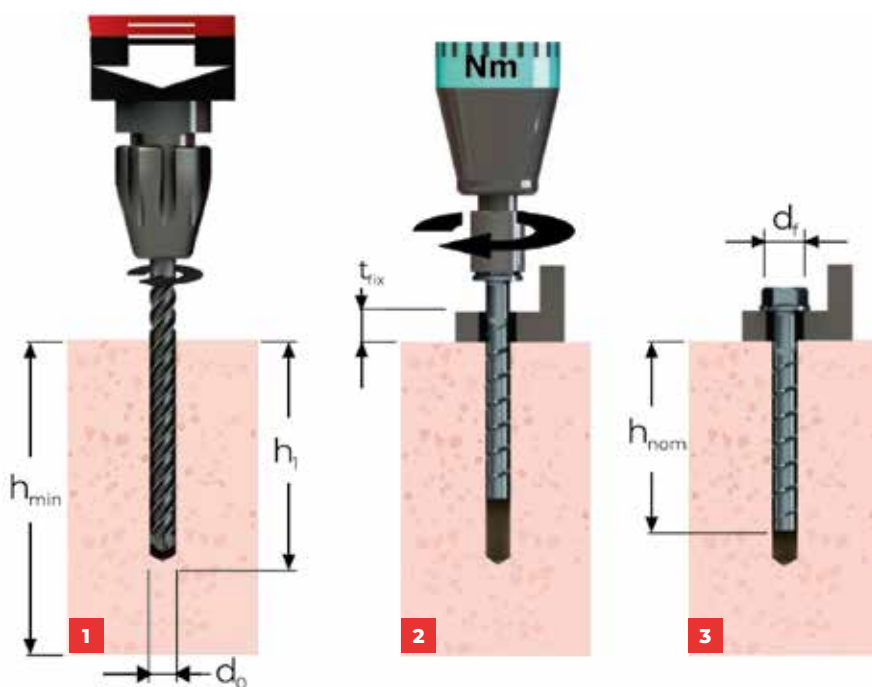

- 1** Drill hole in hammer or rotary mode.
- 2** Screw in with impact screw driver, cordless screw driver or wrench according to the respective stone and size.
- 3** The head must be undamaged and in contact with the fixture. It must not be possible to turn the screw, $T_{inst \max}$ must not be exceeded.

Adjustability for installation in masonry

See p. 29 Installation instructions for adjustment for Sizen 6 to 14 (installation in concrete). The installation data for bricks in masonry must be observed.

01 TOGE TSM HIGH PERFORMANCE

INSTALLATION OPTIONS

Possible installation options in masonry

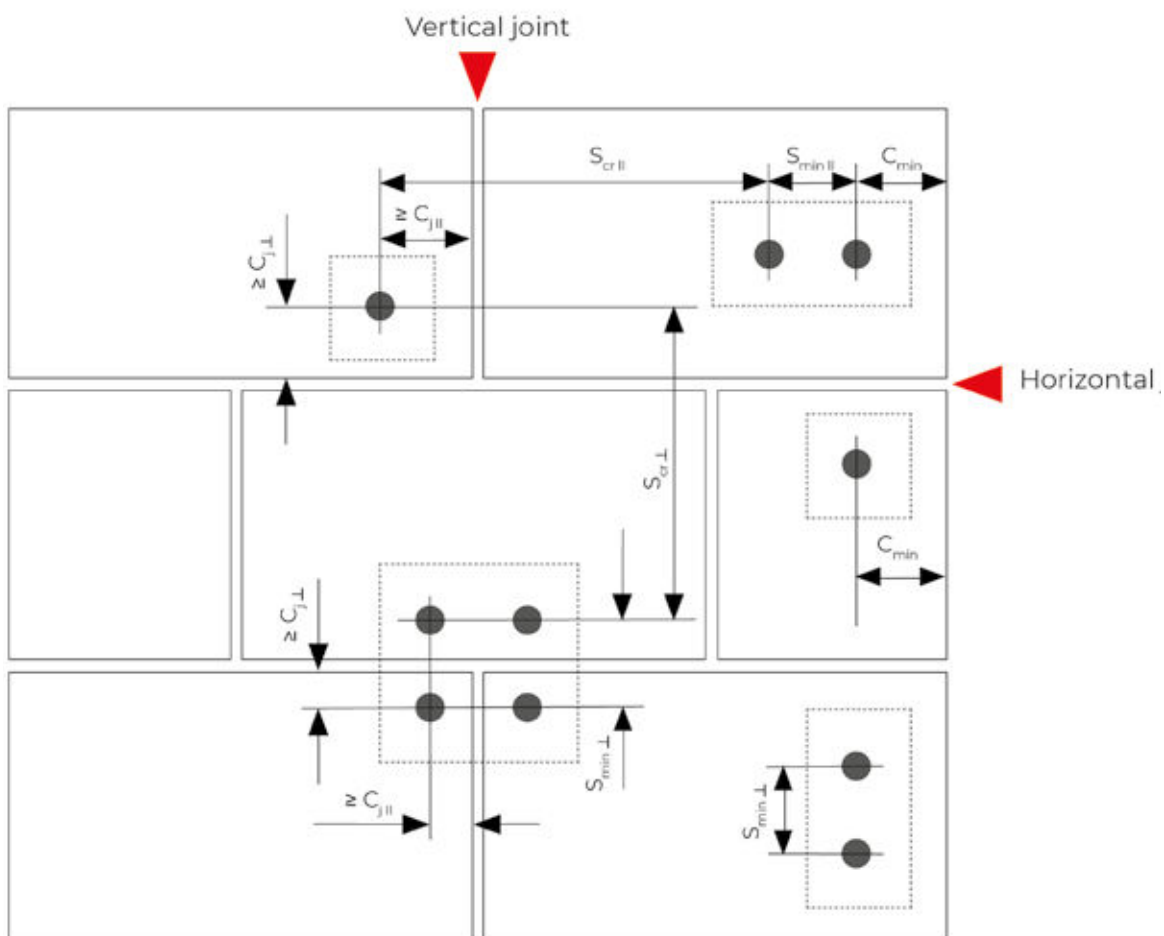

C_{min} = Minimum edge distance to the free edge of the wall

$C_{j II}$ = Distance to vertical joints

$C_{j \perp}$ = Distance to horizontal joints

$S_{min II}$ = Minimum spacing parallel to horizontal joint

$S_{min \perp}$ = Minimum spacing perpendicular to horizontal joint

$S_{cr II}$ = Characteristic spacing parallel to horizontal joint

$S_{cr \perp}$ = Characteristic spacing perpendicular to horizontal joint

02 TOGE TSM ECO **NEW**

TOGE TSM ECO

Innovation meets quality:
The economical concrete screw



Especially economical

The innovative and optimized production process enables price savings without compromising on quality. The TOGE TSM ECO is a high-quality product that is still easy on your budget.



Sustainability in focus

By using optimized production processes, we not only reduce manufacturing costs, but also CO₂ emissions. Your decision to use the TOGE TSM ECO concrete screw therefore contributes to a sustainable future without compromising on quality.



Made in Germany

The TOGE TSM ECO concrete screw was developed by an experienced team in Germany and is also manufactured there. This guarantees not only the highest quality standards, but also close cooperation with experts who understand your needs as a user.



Good load values for versatile applications

Whether tensile or shear loads – the TOGE TSM ECO offers outstanding load values that meet your requirements. You can rely on its robustness and stability to securely fasten and reliably hold shelving systems or other attachments.



Easy to install

Thanks to its intelligent design and optimised geometry, it can be screwed into concrete effortlessly, saving you valuable working time and effort.



ETA Approval

With ETA-23/0693, the TOGE TSM ECO concrete screw has a high-quality approval that officially confirms its performance and reliability. It therefore meets the highest quality and safety standards.

Approval



- ✓ European technical assessment ETA-23/0693, single fastening.

Base Materials

- ✓ Approved for concrete strength classes from C20/25 to C50/60.
- ✓ Cracked and non-cracked concrete.



Scan the QR code and go directly to the product page

For example, to view the approvals in detail you only need one click. Feel free to try it out!

02 TOGE TSM ECO **NEW**

HEADSHAPES AND MATERIALS

Steel,
zinc plated

Steel, zinc
flake-coated

Stainless steel
A4



Hexagon head
with pressed-on
washer



Application examples

Fastening of racks in
high-bay warehouses

Fastening
ventilation ducts



Fastening piping

Fastening of railings

02 TOGE TSM ECO NEW

STEEL – ZINC PLATED

Version with hexagon head and pressed on washer



Size
8
10

Washer-Ø
16,0 mm
20,0 mm

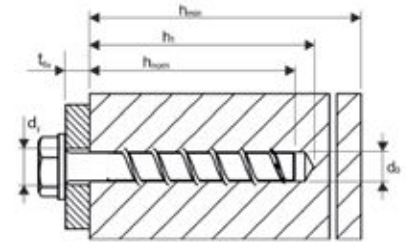

Item nr.	Designation	Depth of drill hole $h_{o1} / h_{o2} / h_{o3}$	Embedment depth of anchor $h_{nom1} / h_{nom2} / h_{nom3}$	Max. thickness of fixture $t_{fix1} / t_{fix2} / t_{fix3}$	Packing Unit
600 008 060	TSM ECO 8x60 SW13	55mm / 65mm / -	45mm / 55mm / -	15mm / 5mm / -	50
600 008 070	TSM ECO 8x70 SW13	55mm / 65mm / 75mm	45mm / 55mm / 65mm	25mm / 15mm / 5mm	50
600 008 080	TSM ECO 8x80 SW13	55mm / 65mm / 75mm	45mm / 55mm / 65mm	35mm / 25mm / 15mm	50
600 008 100	TSM ECO 8x100 SW13	55mm / 65mm / 75mm	45mm / 55mm / 65mm	55mm / 45mm / 35mm	50
600 010 060	TSM ECO 10x60 SW 15	65mm / - / -	55mm / - / -	5mm / - / -	50
600 010 080	TSM ECO 10x80 SW15	65mm / 85mm / -	55mm / 75mm / -	25mm / 5mm / -	50
600 010 090	TSM ECO 10x90 SW15	65mm / 85mm / 95mm	55mm / 75mm / 85mm	35mm / 15mm / 5mm	50
600 010 100	TSM ECO 10x100 SW15	65mm / 85mm / 95mm	55mm / 75mm / 85mm	45mm / 25mm / 15mm	50
600 010 120	TSM ECO 10x120 SW15	65mm / 85mm / 95mm	55mm / 75mm / 85mm	65mm / 45mm / 35mm	50



Structural engineering: New product catalog

Get to know our new product catalog on fastening solutions for structural engineering.

More on page 48



02 TOGE TSM ECO **NEW**

TECHNICAL CHARACTERISTICS

Single fastening without fire exposure, Steel

Screw size TSM E			TSM 8			TSM 10		
Nominal embedment depth	h _{nom}	[mm]	h _{nom1}	h _{nom2}	h _{nom3}	h _{nom1}	h _{nom2}	h _{nom3}
			45	55	65	55	75	85
Nominal diameter of drill bit	d ₀	[mm]	8			10		
Depth of drill hole	h _{0 min}	[mm]	55	65	75	65	85	95
Effective anchorage depth	h _{ef}	[mm]	35	44	52	43	60	69
Diameter of clearance hole in the fixture	d _{i max}	[mm]	12			14		
Approved tension load in cracked concrete ^{1),2)}	N _{zul}	[kN]	1,4	2,6	3,8	2,9	6,2	8,1
Approved shear load in cracked concrete ^{1),2)}	V _{zul}	[kN]	7,1	7,7	9,7	11,6	19,1	19,4
Approved tension load in non-cracked concrete ^{1),2)}	N _{zul}	[kN]	4,2	5,7	8,1	5,2	9,0	11,9
Approved shear load in non-cracked concrete ^{1),2)}	V _{zul}	[kN]	7,7	7,7	9,7	12,9	19,4	19,4
Permissible bending moment	M _{zul}	[kN]	14,9			32,0		
Minimum edge distance	C _{min}	[mm]	35			40		
Minimum spacing	S _{min}	[mm]	35			40		
Minimum Basements thickness	h _{min}	[mm]	80	100	120	100	130	
Maximum torque (with impact screw driver)		[Nm]	300			450		
ETA Seismic C1			No	No	No	No	No	No

¹⁾ For the determination of the approved loads, the partial safety factor from the approval $\gamma_M=1,5$ was taken into account for material resistance and a partial safety factor $\gamma_F=1,4$ for load actions.

²⁾ These values apply without influence of the spacing and edge distances.

02 TOGE TSM ECO **NEW**

TECHNICAL CHARACTERISTICS

Single fastening under fire exposure, Steel

Screw size TSM E				TSM 8			TSM 10		
Nominal embedment depth		h_{nom}	[mm]	h_{nom1}	h_{nom2}	h_{nom3}	h_{nom1}	h_{nom2}	h_{nom3}
				45	55	65	55	75	85
Permissible load under tensile and shear use ($F_{zul,fi} = N_{zul,fi} = V_{zul,fi}$)									
Fire resistance class									
R 30	Approved load	$F_{zul,fi 30}$	[kN]	0,8	1,4	2,0	1,5	3,3	4,3
R 60		$F_{zul,fi 60}$	[kN]	0,8	1,4	1,7	1,5	3,3	3,3
R 90		$F_{zul,fi 90}$	[kN]	0,8	1,1	1,1	1,5	2,3	2,3
R 120		$F_{zul,fi 120}$	[kN]	0,6	0,7	0,7	1,2	1,7	1,7
R 30		$M_{zul,fi 30}$	[Nm]	2,4			5,9		
R 60		$M_{zul,fi 60}$	[Nm]	1,8			4,5		
R 90		$M_{zul,fi 90}$	[Nm]	1,2			3,0		
R 120		$M_{zul,fi 120}$	[Nm]	0,9			2,3		
Edge distance									
R 30 to R 120		$C_{cr,fi}$	[mm]	$2 \times h_{ef}$					
The edge distance must be at least 300 mm if the fire load attacks from more than one side.									
Spacing									
R 30 to R 120		$S_{cr,fi}$	[mm]	$4 \times h_{ef}$					
Concrete pry-out failure									
R 30 to R 120		k	[-]	2,1	2,8		2,5		
In wet concrete, the embedment depth must be increased by at least 30 mm.									

02 TOGE TSM ECO **NEW**

INSTALLATION INSTRUCTIONS

Installation instructions

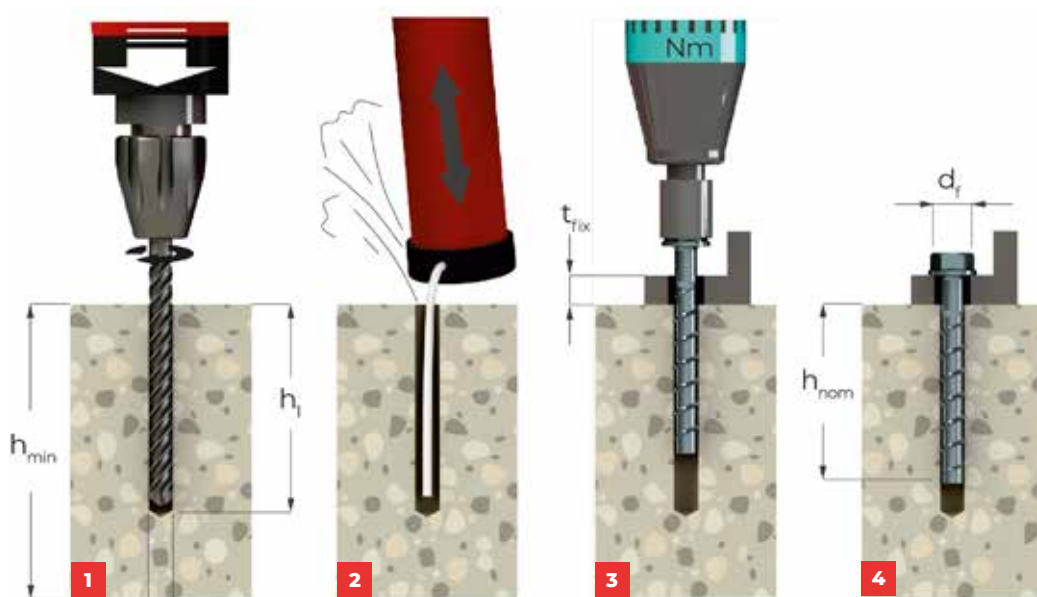

- 1** Create borehole.
- 2** Clean the borehole thoroughly.
- 3** Screw in concrete screw TOGE TSM ECO.
- 4** The screw head must rest completely on the attachment.

02 TOGE TSM ECO **NEW**

INSTALLATION INSTRUCTIONS

Installation instructions with adjustment for sizes 8 to 10

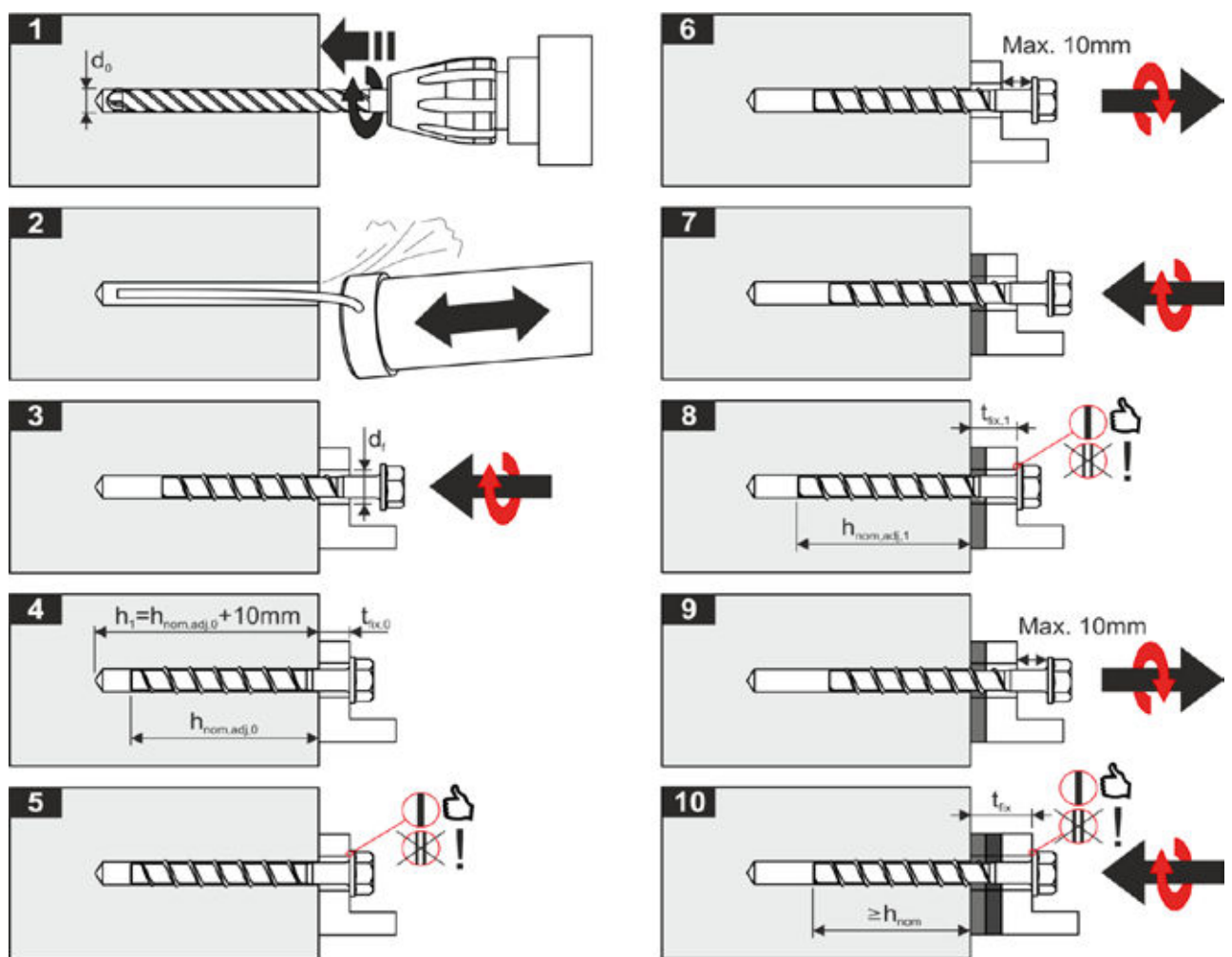

⚠ Important – please note during adjustment:

1. The anchor may be adjusted maximum two times, while the anchor may turn back at most 10 mm.
2. The total allowed thickness of shims added during the adjustment process is 10 mm.
3. The final embedment depth after adjustment process must be equal or longer than h_{nom} .

03 TOGE TSM BC ST

TOGE TSM BC ST

Concrete screw for construction site safety and temporary fixation



Fast and safe installation

The optimized thread enables a fast and safe installation process.



Temporary fastening

For temporary fastening also in outdoor areas.



High loads

High load bearing capacity in cracked and non-cracked concrete.



Easily demountable

Residual disassembly and therefore reusable.



Special approval

Anchoring of site equipment in fresh concrete.

Approval



- ✓ General design approval Z-21.8.2115 for temporary fastening.

Base Materials

- ✓ Application in concrete with a compressive strength of $\geq 10 \text{ N/mm}^2$.
- ✓ Cracked and non-cracked concrete.





**Scan the QR code and go
directly to the product page**

For example, to view the approvals in detail
you only need one click. Feel free to try it out!

03 TOGE TSM BC ST

HEADSHAPES AND MATERIALS

		Steel, zinc plated	Steel, zinc flake-coated	Steel, stainless A4
	Hexagon head with collar	✓		
	Hexagon head with pressed on washer	✓	✓	
	Sleeve gauge	✓		

Application examples



Fastening of guardrails, scaffolding or formwork props

03 TOGE TSM BC ST

STEEL – ZINC PLATED

Version with hexagonal head and collar



Size
14

Washer-Ø
32,0 mm

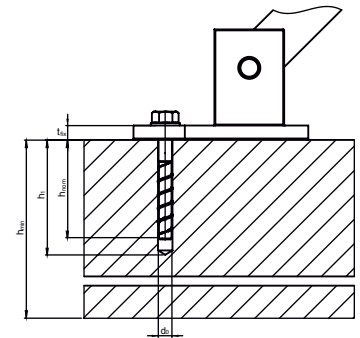

Item nr.	Designation	Depth of drill hole $h_{01} / h_{02} / h_{03}$	Embedment depth of anchor $h_{nom1} / h_{nom2} / h_{nom3}$	Max. thickness of fixture $t_{fix1} / t_{fix2} / t_{fix3}$	Packing Unit
377 014 134 *	TSM BC ST 14 x 130 SW24	85 mm / 100 mm / 125 mm	75 mm / 90 mm / 115 mm	55 mm / 40 mm / 15 mm	25

* Sleeve gauge already included

Version with hexagonal head and pressed on washer



Size
10
12
14

Washer-Ø
20,0 mm
23,5 mm
28,5 mm

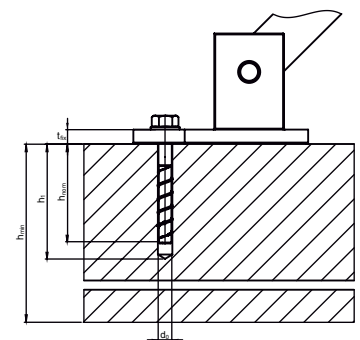

Item nr.	Designation	Depth of drill hole $h_{01} / h_{02} / h_{03}$	Embedment depth of anchor $h_{nom1} / h_{nom2} / h_{nom3}$	Max. thickness of fixture $t_{fix1} / t_{fix2} / t_{fix3}$	Packing Unit
300 010 090	TSM 10x90 SW15	85mm	75mm	15mm	50
300 010 100	TSM 10x100 SW15	85mm	75mm	25mm	50
300 010 120	TSM 10x120 SW15	85mm	75mm	45mm	50
300 010 140	TSM 10x140 SW15	85mm	75mm	65mm	50
300 010 150	TSM 10x150 SW15	85mm	75mm	75mm	50
300 010 160	TSM 10x160 SW15	85mm	75mm	85mm	50
300 010 180	TSM 10x180 SW15	85mm	75mm	105mm	25
300 010 200	TSM 10x200 SW15	85mm	75mm	125mm	25
300 010 240	TSM 10x240 SW15	85mm	75mm	165mm	25
300 010 280	TSM 10x280 SW15	85mm	75mm	205mm	25
300 012 110	TSM 12x110 SW17	85mm / 100mm / -	75mm / 90mm / -	35mm / 20mm / -	25
300 012 130	TSM 12x130 SW17	85mm / 100mm / -	75mm / 90mm / -	55mm / 40mm / -	25
300 012 150	TSM 12x150 SW17	85mm / 100mm / -	75mm / 90mm / -	75mm / 60mm / -	25
300 014 110	TSM 14x110 SW21	85mm / 100mm / -	75mm / 90mm / -	35mm / 20mm / -	25
300 014 130	TSM 14x130 SW21	85mm / 100mm / 125mm	75mm / 90mm / 115mm	55mm / 40mm / 15mm	25
300 014 150	TSM 14x150 SW21	85mm / 100mm / 125mm	75mm / 90mm / 115mm	75mm / 60mm / 35mm	25

03 TOGE TSM BC ST

**STEEL -
ZINC FLAKE-COATED**

Version with hexagon head and pressed on washer



Size	Washer-Ø
10	20,0 mm
12	23,5 mm
14	28,5 mm

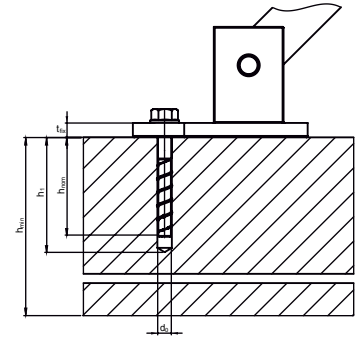

Item nr.	Designation	Depth of drill hole h _{o1} / h _{o2} / h _{o3}	Embedment depth of anchor h _{nom1} / h _{nom2} / h _{nom3}	Max. thickness of fixture t _{fix1} / t _{fix2} / t _{fix3}	Packing Unit
400 010 090	TSM 10x90 SW15	85mm	75mm	15mm	50
400 010 100	TSM 10x100 SW15	85mm	75mm	25mm	50
400 010 120	TSM 10x120 SW15	85mm	75mm	45mm	50
400 010 140	TSM 10x140 SW15	85mm	75mm	65mm	50
400 010 150	TSM 10x150 SW15	85mm	75mm	75mm	50
400 010 160	TSM 10x160 SW15	85mm	75mm	85mm	50
400 010 180	TSM 10x180 SW15	85mm	75mm	105mm	25
400 010 200	TSM 10x200 SW15	85mm	75mm	125mm	25
400 010 240	TSM 10x240 SW15	85mm	75mm	165mm	25
400 010 280	TSM 10x280 SW15	85mm	75mm	205mm	25
400 012 110	TSM 12x110 SW17	85mm / 100mm / -	75mm / 90mm / -	35mm / 20mm / -	25
400 012 130	TSM 12x130 SW17	85mm / 100mm / -	75mm / 90mm / -	55mm / 40mm / -	25
400 012 150	TSM 12x150 SW17	85mm / 100mm / -	75mm / 90mm / -	75mm / 60mm / -	25
400 014 110	TSM 14x110 SW21	85mm / 100mm / -	75mm / 90mm / -	35mm / 20mm / -	25
400 014 130	TSM 14x130 SW21	85mm / 100mm / 125mm	75mm / 90mm / 115mm	55mm / 40mm / 15mm	25
400 014 150	TSM 14x150 SW21	85mm / 100mm / 125mm	75mm / 90mm / 115mm	75mm / 60mm / 35mm	25
400 014 110	TSM 14x110 SW21 ZFC	85mm / 110mm / -	75mm / 100mm / -	35mm / 10mm / -	25
400 014 130	TSM 14x130 SW21 ZFC	85mm / 110mm / 125mm	75mm / 100mm / 115mm	55mm / 30mm / 15mm	25
400 014 150	TSM 14x150 SW21 ZFC	85mm / 110mm / 125mm	75mm / 100mm / 115mm	75mm / 50mm / 35mm	25

Sleeve gauge
(please order seperately)



Item nur.	Designation	Packing Unit
377 010 001	Sleeve gauge for concrete screw size 10	10
377 012 001	Sleeve gauge for concrete screw size 12	10
377 014 001	Sleeve gauge for concrete screw size 14	10

03 TOGE TSM BC ST

TECHNICAL CHARACTERISTICS

Without fire exposure, Steel

Screw size TSM BC ST & TSM High Performance			TSM 10	TSM 12		TSM 14		
Nominal embedment depth	h _{nom}	[mm]	h _{nom,1}	h _{nom,1}	h _{nom,2}	h _{nom,1}	h _{nom,2}	h _{nom,3}
			75	75	90	75	90	115
Nominal diameter of drill bit	d ₀	[mm]	10	12		14		
Depth of drill hole	h _{1 min}	[mm]	85	85	100	85	100	125
Minimum Basements thickness	h _{min}	[mm]	150	150	195	150	195	200 225
Approved tension load in cracked concrete with compressive strenght f _{ck,cube} 10 N/mm ^{1) 2)}	N _{zul}	[kN]	4,3	4,3	8,6	4,3	8,6	10,7 12,1
Approved tension load in cracked concrete with compressive strenght f _{ck,cube} 15 N/mm ^{1) 2)}	N _{zul}	[kN]	5,0	5,0	9,3	5,0	9,3	12,9 15,0
Approved tension load in cracked concrete with compressive strenght f _{ck,cube} 20 N/mm ^{1) 2)}	N _{zul}	[kN]	5,7	5,7	10,0	5,7	10,0	14,3 17,1
Minimum edge distance in load direction ¹⁾	C ₁	[mm]	105	105	130	105	130	165
Minimum edge distance crosswise to load direction ¹⁾	C ₂	[mm]	160	160	195	160	195	250
Minimum spacing	S _{min}	[mm]	320	320	390	320	390	500
Maximum torque (with impact screw driver)		[Nm]	400	650		650		

¹⁾ See drawing.

²⁾ The partial safety for load actions γ_F=1,4 were considered for determining the load.

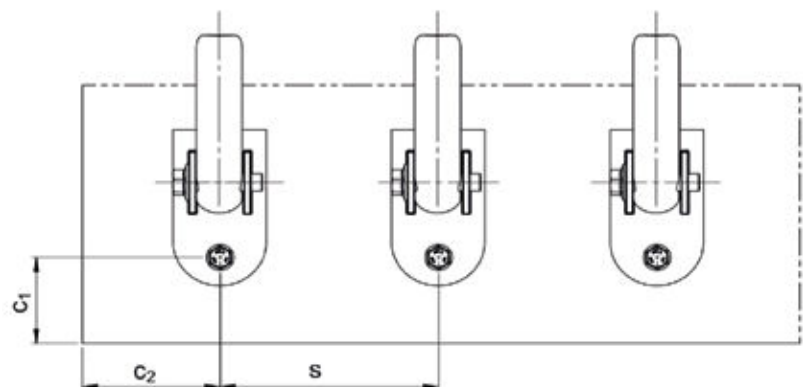

03 TOGE TSM BC ST

INSTALLATION INSTRUCTIONS

Important notice before installation

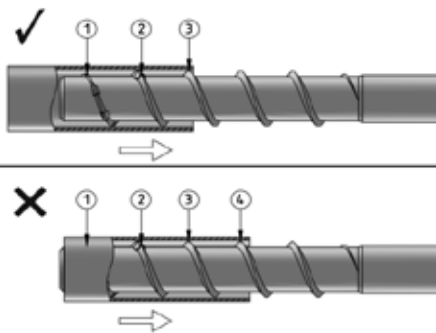

1. Before each reuse, the degree of wear on the thread must be checked with an appropriate ring gauge.
2. The concrete screw may only be reused if no more than 3 turns of the thread can enter into the ring gauge.
3. Screws with visible damage, e.g. caused by corrosion wear, must not be reused as a rule.

Installation instructions

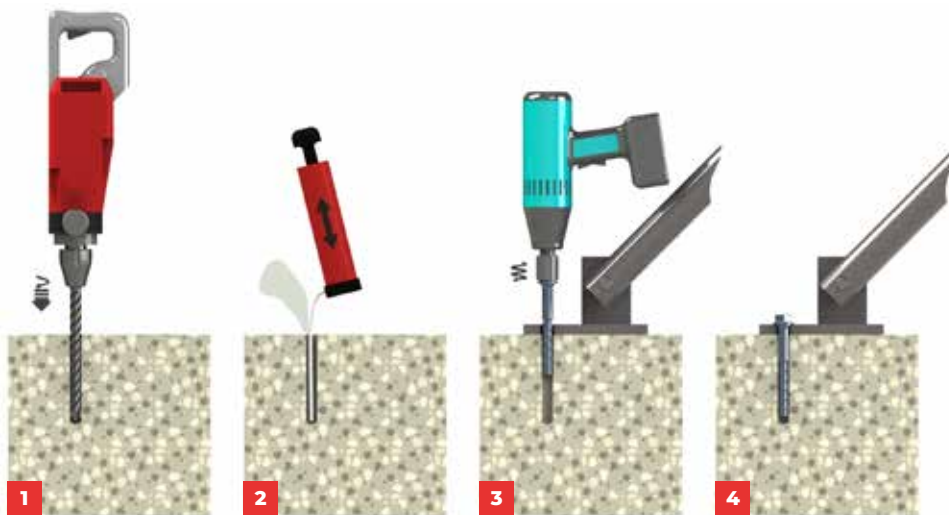

- 1 Create borehole.
- 2 Clean the borehole thoroughly.
- 3 Screw in concrete screw TOGE TSM High Performance.
- 4 The screw head must rest completely on the attachment.

NEW!

PRODUCT CATALOGUE: FASTENING SOLUTIONS FOR STRUCTURAL ENGINEERING

PRODUCT OVERVIEW

See page 86 of
the catalogue

Get to know our product solutions
for structural engineering

Do you already know our special catalogue for
fastening solutions in structural engineering?
This catalogue offers a comprehensive selection
of high-quality fastening solutions that are tailored
to the special requirements and challenges of
this particular application.

TO CATALOGUE



toge.de

04 TOGE TSM MULTIGROUND **NEW**

TOGE TSM MULTIGROUND

Female threaded screw
for various substrates



Easy Installation

Easy, fast and safe installation with an impact screwdriver. This makes overhead work in particular much easier.



Easily demountable

If required, the TOGE TSM Multi-ground can be quickly and easily dismantled.



Flush with surface

The flush surface installation results in a clean installation appearance without any interfering elements.



High load values

The special thread geometry ensures a secure hold and high loads in concrete.



Internal thread

The practical internal thread enables use for a wide range of applications.



Small edge distances

Small edge distances and spacing allow particularly close-edge and closely spaced installation.



Approval



- ✓ European technical assessment ETA-23/0542.

Base Material

- ✓ Approved for concrete strength classes from C20/25 to C50/60.
- ✓ Cracked and non-cracked concrete.
- ✓ Suitable for masonry, aerated concrete and wood.



Scan the QR code and go directly to the product page

For example, to view the approvals in detail you only need one click. Feel free to try it out!

04 TOGE TSM MULTIGROUND **NEW**

HEADSHAPES AND MATERIALS

Steel,
zinc plated

Steel, zinc
flake-coated

Stainless Steel
A4



Female thread
M6, M8, M10



Application examples

Fastening of
cable ducts

Fastening of ceiling
suspension of any kind



Fastening of piping

Detail: TSM Multiground
with threaded rod
and pipe clamp

04 TOGE TSM MULTIGROUND NEW

STEEL – ZINC PLATED

Version with female thread



Size
8
10
12

Ø Female thread
M6
M8
M10

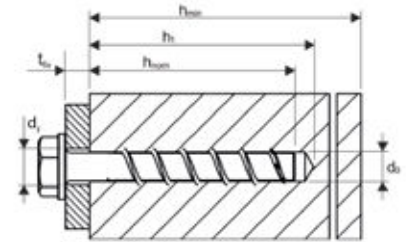

Item nr.	Designation	Depth of drill hole h_1	Embedment depth h_{nom}	Length female thread L_{Gew}	Packung Unit
345 008 040	TSM M 8x40 IM6x10 VZ50	50mm	40mm	10 mm	100
345 010 040	TSM M 10x40 IM8x10 VZ55	50mm	40mm	10 mm	100
345 012 040	TSM M 12x40 IM10x10 VZ60	50mm	40mm	10 mm	100



**Determine your needs correctly:
With our free anchor design software**

Our user-friendly software for dimensioning fasteners of fasteners is free of charge.

More on page 56



04 TOGE TSM MULTIGROUND NEW

TECHNICAL CHARACTERISTICS

Multiple fastening without fire exposure, Steel

Screw size TSM M				TSM 8 M	TSM 10 M	TSM 12 M
Nominal embedment depth	h_{nom}	[mm]		40	40	40
Nominal diameter of drill bit	d_0	[mm]		8	10	12
Depth of drill hole	h_1 min	[mm]		50	50	50
Effective anchorage depth	h_{ef}	[mm]		31	31	30
Diameter of clearance hole in the fixture	d_f max	[mm]		7	9	12
Minimum edge distance	c_{min}	[mm]		40	40	40
Minimum spacing	s_{min}	[mm]		30	40	40
Minimum Basements thickness	h_{min}	[mm]		80	80	80
Installation torque (for metrical thread)	T_{inst}	[Nm]		4	8	15
Minimum screw-in depth metrical thread		[mm]		8	8	8
Maximum torque (with impact screw driver)		[Nm]		180	180	180
Permissible load for metrical thread of tension class 4.8						
Permissible tension load in cracked concrete ^{1) 3)}	N_{zul}	4.8	[kN]	2,6	2,8	1,8
Permissible shear load in cracked concrete ^{2) 3)}	V_{zul}	4.8	[kN]	2,3	2,8	2,3
Permissible tension load in uncracked concrete ^{1) 3)}	N_{zul}	4.8	[kN]	3,1	3,8	2,2
Permissible shear load in uncracked concrete ^{2) 3)}	V_{zul}	4.8	[kN]	2,3	4,0	3,2
Permissible bending moment ^{2) 3)}	M_{zul}	4.8	[kN]	2,9	7,1	13,7
Permissible load for metrical thread of tension class 5.8						
Permissible tension load in cracked concrete ^{1) 3)}	N_{zul}	5.8	[kN]	2,6	2,8	1,8
Permissible shear load in cracked concrete ^{2) 3)}	V_{zul}	5.8	[kN]	2,8	2,8	2,3
Permissible tension load in uncracked concrete ^{1) 3)}	N_{zul}	5.8	[kN]	3,1	3,8	2,2
Permissible shear load in uncracked concrete ^{2) 3)}	V_{zul}	5.8	[kN]	2,9	4,0	3,2
Permissible bending moment ^{2) 3)}	M_{zul}	5.8	[kN]	3,6	8,8	13,7
Permissible load for metrical thread of tension class 8.8						
Permissible tension load in cracked concrete ^{1) 3)}	N_{zul}	8.8	[kN]	2,6	2,8	1,8
Permissible shear load in cracked concrete ^{2) 3)}	V_{zul}	8.8	[kN]	2,8	2,8	2,3
Permissible tension load in uncracked concrete ^{1) 3)}	N_{zul}	8.8	[kN]	3,1	3,8	2,2
Permissible shear load in uncracked concrete ^{2) 3)}	V_{zul}	8.8	[kN]	3,4	4,0	3,2
Permissible bending moment ^{2) 3)}	M_{zul}	8.8	[kN]	5,0	8,8	13,7

¹⁾ For the determination of the approved loads, the partial safety factor from the approval $\gamma_M=1,5$ was taken into account for material resistance and a partial safety factor of $\gamma_F=1,4$ for load actions.

²⁾ For the determination of the approved loads, the partial safety factor from the approval $\gamma_M=1,25$ was taken into account for material resistance and a partial safety factor of $\gamma_F=1,4$ for load actions.

³⁾ These values apply without influence of the spacing and edge distances.

04 TOGE TSM MULTIGROUND NEW

TECHNICAL CHARACTERISTICS

Multiple fastening under fire exposure, Steel

Screw size TSM M			TSM 8 M	TSM 10 M	TSM 12 M
Nominal embedment depth		h_{nom} [mm]	40	40	40
Permissible load under tensile and shear use ($F_{zul,fi} = N_{zul,fi} = V_{zul,fi}$) ^{1) 2)}					
Fire resistance class					
R 30	Approved load	$F_{zul,fi 30}$ [kN]	0,9	0,9	0,8
R 60		$F_{zul,fi 60}$ [kN]	0,9	0,9	0,8
R 90		$F_{zul,fi 90}$ [kN]	0,9	0,9	0,8
R 120		$F_{zul,fi 120}$ [kN]	0,7	0,7	0,7
R 30		$M_{zul,fi 30}$ [Nm]	0,63	1,81	4,28
R 60		$M_{zul,fi 60}$ [Nm]	0,49	1,36	3,12
R 90		$M_{zul,fi 90}$ [Nm]	0,34	0,91	1,97
R 120		$M_{zul,fi 120}$ [Nm]	0,27	0,68	1,39
Edge distance					
R 30 to R 120		$C_{cr,fi}$ [mm]	$2 \times h_{ef}$		
The edge distance must be at least 300 mm if the fire load attacks from more than one side.					
Spacing					
R 30 to R 120		$S_{cr,fi}$ [mm]	$4 \times h_{ef}$		
Concrete pry-out failure					
R 30 to R 120		k	1,0		
In wet concrete, the embedment depth must be increased by at least 30 mm.					

¹⁾ For the determination of the approved loads, the partial safety factor from the approval $\gamma_M=1,0$ was taken into account for material resistance and a partial safety factor of $\gamma_F=1,0$ for load actions.

²⁾ These values apply without influence of the spacing and edge distances.

04 TOGE TSM MULTIGROUND **NEW**

INSTALLATION INSTRUCTIONS

Installation instructions

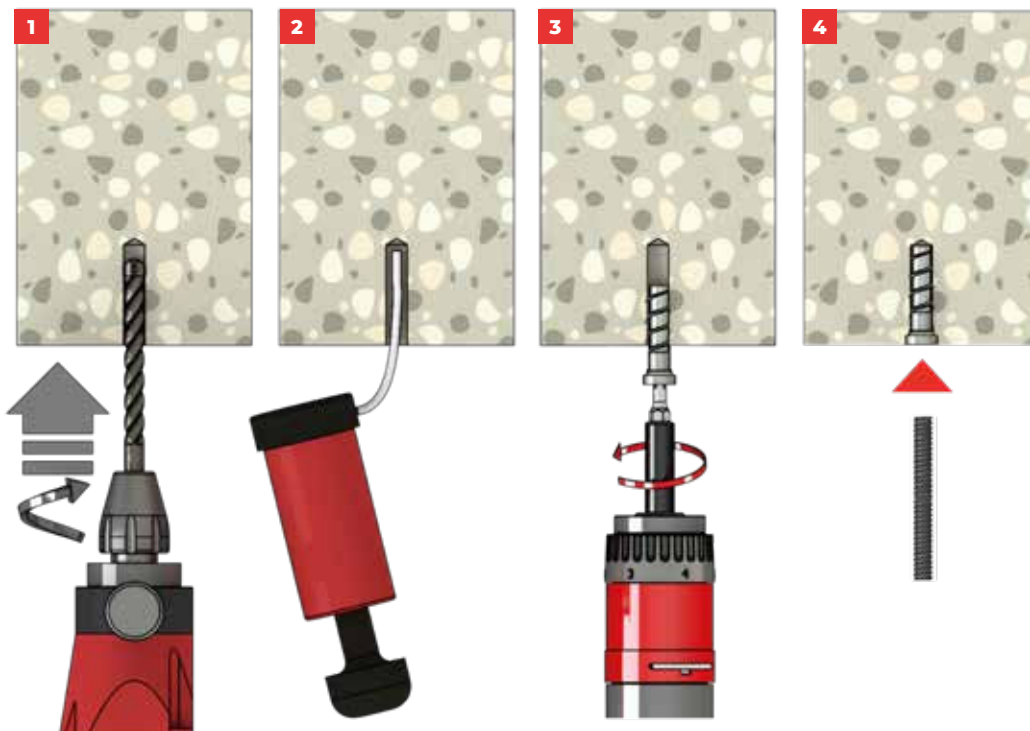

- 1** Create drill hole with hammerdrill or hollow drill bit.
- 2** Clean the borehole thoroughly.
- 3** Screw in TOGE TSM Multiground with impact screwdriver or wrench.
- 4** Screw must be screwed in flush with the surface of the concrete. The attachment part is fastened with a standard metric screw or threaded rod. The tightening torque of the metric thread must be observed.

Request Now!

DETERMINE YOUR NEEDS CORRECTLY: WITH OUR FREE ANCHOR DESIGN SOFTWARE



NEW

Calculation acc.
to **DIN EN 1992-4:**
2018-04

Design Software:

The user-friendly tool for the design of fasteners in concrete

With our free DesignFIX anchor design software, you can easily determine the right anchor requirements. The software makes it possible to carry out dimensioning according to the latest guidelines and select the right product for your application.

TO WEBSITE

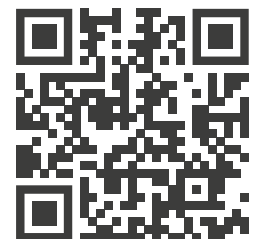

toge.de/en/software

05 TOGE TSM L

TOGE TSM L

Concrete screw for interior and drywall construction



Fast Installation

A small drilling diameter of just 6 mm ensures fast and easy drilling progress – even in high-strength concrete.



No more reinforcement hits

The low embedment depths of 25 mm and 35 mm allow particularly user-friendly processing completely WITHOUT reinforcement hits.



Easy Installation

The patented special thread of the TOGE TSM L allows installation with a standard cordless screwdriver without the need for additional special tools.



Particularly near the edge

Small edge distances and spacing allow very closed-edge and closely spaced installation.



Variable load absorption

Two different embedment depths of 25 mm or 35 mm allow variable load absorption – tailored to your individual application requirements.



Easily demountable

If required, the TOGE TSM L can be quickly and easily demounted again. This means that drywall can be removed and reinstalled afterwards.

Approval



- ✓ European technical assesment ETA-15/0055.

Basements

- ✓ Approved for concrete strenght classes from C20/25 to C50/60.
- ✓ Cracked and non-cracked concrete.







Scan the QR code and go directly to the product page

For example, to view the approvals in detail you only need one click. Feel free to try it out!

05 TOGE TSM L

HEADSHAPES AND MATERIALS

		Steel zinc-plated	Steel, zinc flake-coated	Stainless steel A4
	Panhead and multipoint drive	✓		
	Large panhead and multipoint drive	✓		
	Metric connection thread M8	✓		
	Metric connection thread M6	✓		
	Metric female thread M8/M10	✓		

Application examples

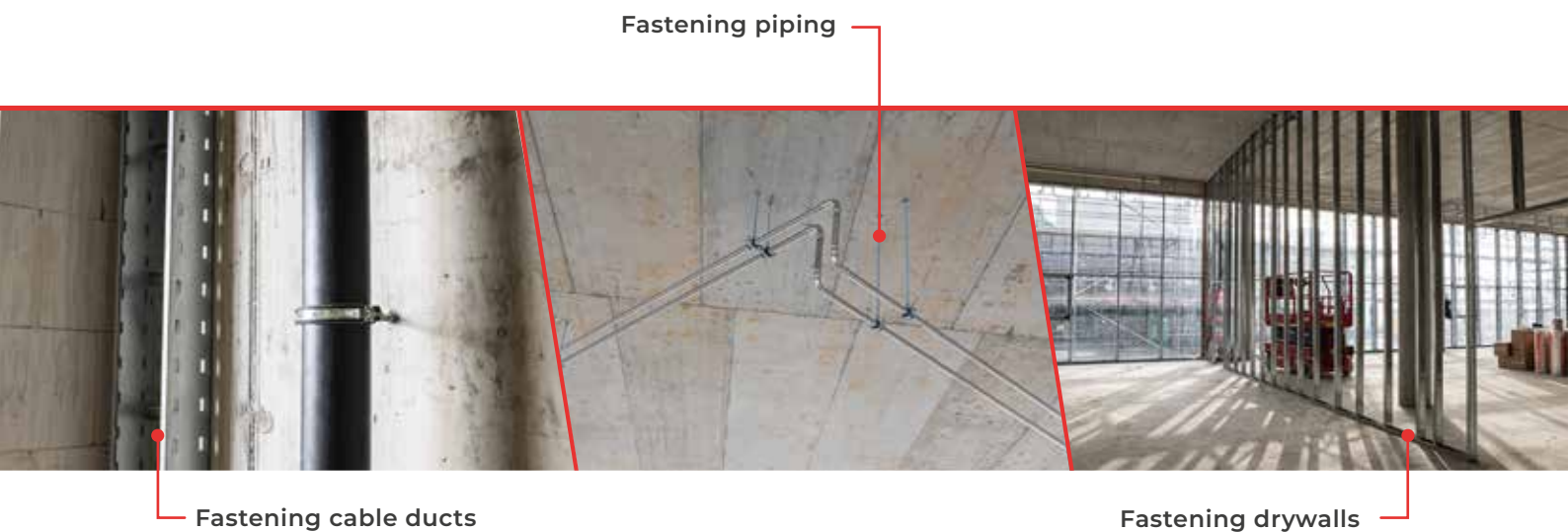

Fastening piping

Fastening cable ducts

Fastening drywalls

05 TOGE TSM L

STEEL – ZINC PLATED

Version with panhead and multipoint drive



Size
6

Head-Ø
14,0 mm

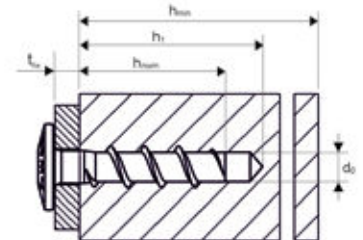

Item nr.	Designation	Depth of drill hole $h_{1,1}$	Embedment depth of anchor $h_{nom,1}$	Max. thickness of fixture $t_{fix,1}$	Packing Unit
205 060 280	TSM L 6x28 LiKo VZ30	28 mm	25 mm	3 mm	100

Version with large panhead and multipoint drive



Size
6

Head-Ø
17,5 mm

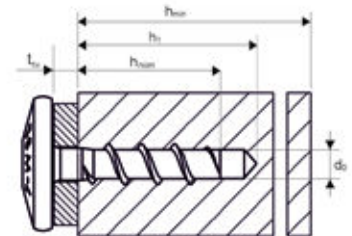

Item nr.	Designation	Depth of drill hole $h_{1,1} / h_{1,2}$	Embedment depth of anchor $h_{nom,1} / h_{nom,2}$	Max. thickness of fixture $t_{fix,1} / t_{fix,2}$	Packing Unit
205 060 281	TSM L 6x28 LP VZ30	28 mm	25 mm	3 mm	100
205 060 401	TSM L 6x40 LP VZ30	28 mm 38 mm	25 mm 35 mm	15 mm 5 mm	100

05 TOGE TSM L

STEEL – ZINC PLATED

Version with metric connection thread M8

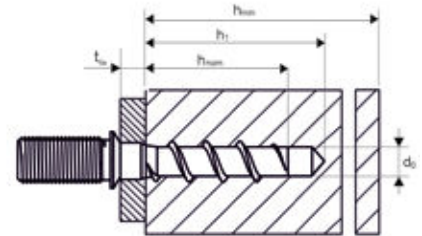

Item nr.	Designation	Depth of drill hole $h_{1,1}$	Embedment depth of anchor $h_{nom,1}$	Max. thickness of fixture $t_{fix,1}$	Packing Unit
205 060 283	TSM L 6x28 M8 VZ25	28 mm	25 mm	3 mm	100

Version with metric connection thread M6

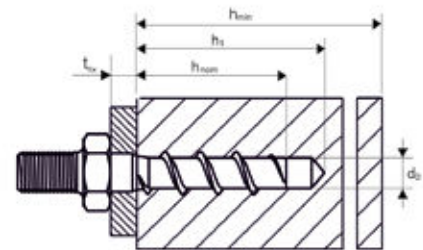

Item nr.	Designation	Depth of drill hole $h_{1,1}$	Embedment depth of anchor $h_{nom,1}$	Max. thickness of fixture $t_{fix,1}$	Packing Unit
205 060 282	TSM L 6x28 M6 SW10	28 mm	25 mm	3 mm	100

05 TOGE TSM L

STEEL – ZINC PLATED

Version with metric female thread
M8/M10



Size
6

Washer-Ø
25,0 mm

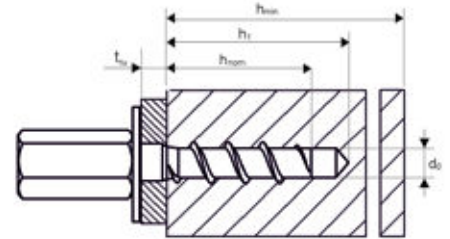

Item nr.	Designation	Depth of drill hole $h_{1,1} / h_{1,2}$		Embedment depth of anchor $h_{nom,1} / h_{nom,2}$		Max. thickness of fixture $t_{fix,1} / t_{fix,2}$		Packing Unit
205 060 404	TSM L 6x40 M8/10 SW13	28 mm	38 mm	25 mm	35 mm	15 mm	5 mm	50



**Do you need support?
We will be happy to advise you!**

Call us: +49 911 659 68-43



05 TOGE TSM L

TECHNICAL CHARACTERISTICS

Single fastening without fire exposure, Steel

Screw size TSM L			6	
Nominal embedment depth	h _{nom} [mm]		h _{nom,1}	h _{nom,2}
			25	35
Nominal diameter of drill bit	d ₀	[mm]	6	
Depth of drill hole	h ₁ min	[mm]	28	38
Effective anchorage depth	h _{ef}	[mm]	19	27
Diameter of clearance hole in the fixture	d _f max	[mm]	8	
Approved tension load in cracked concrete ^{1) 2)}	N _{zul}	[kN]	0,4	1,0
Approved shear load in cracked concrete ^{1) 2)}	V _{zul}	[kN]	1,4	2,3
Approved tension load in non-cracked concrete ^{1) 2)}	N _{zul}	[kN]	1,0	1,9
Approved shear load in non-cracked concrete ^{1) 2)}	V _{zul}	[kN]	1,9	3,3
Permissible bending moment	M _{zul}	[kN]	6,3	
Minimum edge distance	C _{min}	[mm]	30	
Minimum spacing	S _{min}	[mm]	30	
Minimum Basements thickness	h _{min}	[mm]	80	
Installation torque (with metric connection thread)	T _{inst}	[Nm]	10	

¹⁾ For the determination of the approved loads, the partial safety factor from the approval $\gamma_M = 1,0$ was taken into account for material resistance and a partial safety factor $\gamma_F = 1,4$ for load actions.

²⁾ These values apply without influence of the spacing and edge distances.

05 TOGE TSM L

TECHNICAL CHARACTERISTICS

Single fastening under fire exposure, Steel

Screw size TSM L				6		
Nominal embedment depth		h _{nom}	[mm]	h _{nom,1}	h _{nom,2}	
				25	35	
Permissible load under tensile and shear use ($F_{zul,fi} = N_{zul,fi} = V_{zul,fi}$)						
Fire resistance class						
R 30	Approved load	F _{zul,fi 30}	[kN]	0,23	0,27	
R 60		F _{zul,fi 60}	[kN]	0,23	0,27	
R 90		F _{zul,fi 90}	[kN]	0,22		
R 120		F _{zul,fi 120}	[kN]	0,17		
R 30		M _{zul,fi 30}	[Nm]	0,22		
R 60		M _{zul,fi 60}	[Nm]	0,22		
R 90		M _{zul,fi 90}	[Nm]	0,18		
R 120		M _{zul,fi 120}	[Nm]	0,14		
Edge distance						
R 30 to R 120		C _{cr,fi}	[mm]	2 x h _{ef}		
The edge distance must be at least 300 mm if the fire load attacks from more than one side.						
Spacing						
R 30 to R 120		S _{cr,fi}	[mm]	4 x h _{ef}		
Concrete pry-out failure						
R 30 to R 120		k	[-]	1,0		
In wet concrete, the embedment depth must be increased by at least 30 mm.						

05 TOGE TSM L

INSTALLATION INSTRUCTIONS

Installation instructions

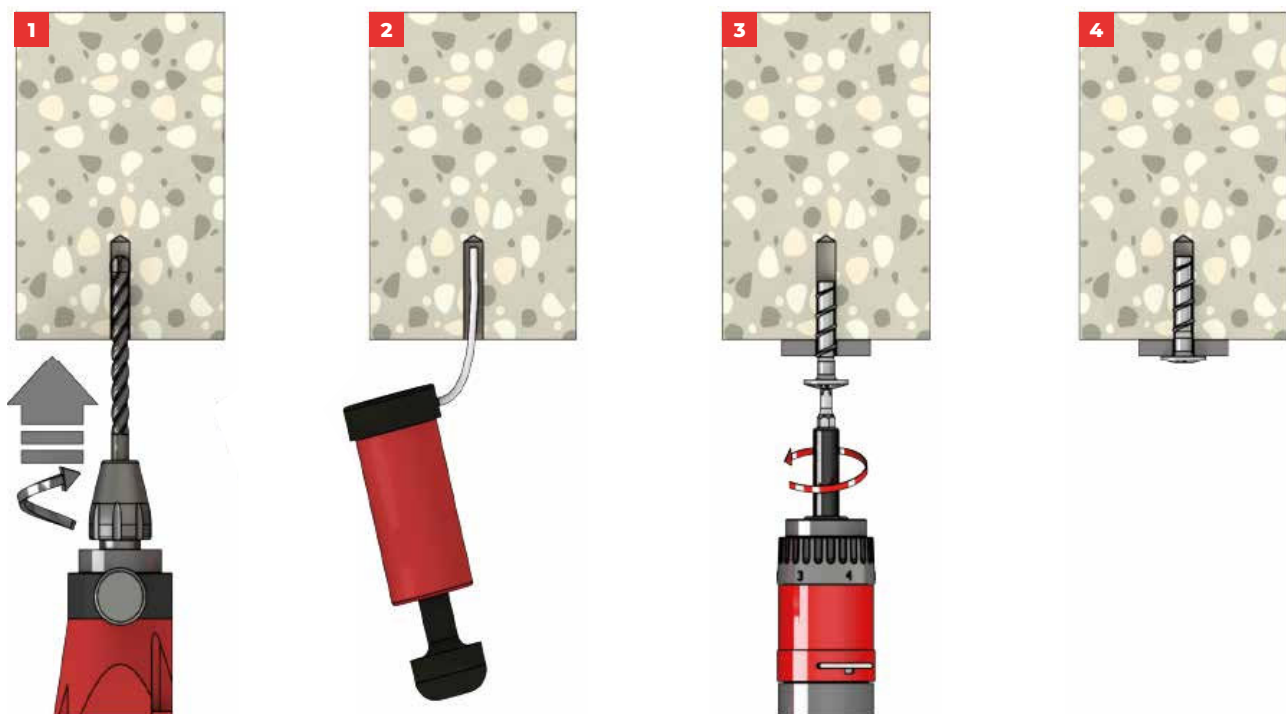

- 1 Create borehole.
- 2 Clean the borehole thoroughly.
- 3 Screw in the TOGE TSM L with a standard cordless screwdriver – without special tools.
- 4 The screw head must rest completely on the attachment.



Own research and development

Our engineers are continuously working on the optimization of our products, development of new products and customized product solutions.

SIDE NOTE

We are celebrating!

THE FASTENING EXPERTS



YEARS

SECURE FASTENING SINCE 1964

- 1964**  **Company Foundation**
The master carpenter Anton Gerhard invents the window frame dowel in Nuremberg and applies for a patent. The ingenious product is initially produced exclusively for HILTI. TOGE Dübel is born.
- 1996**  **We are launching our first concrete screw**
Since 1994, TOGE has been dedicated to the development of a self-tapping concrete screw. This was launched on the market in 1996. This makes us one of the pioneers of concrete screwing technology. Specialisation in this product range since 1997.
- 1997**  **Steel Innovation Award 1997**
TOGE wins 3rd prize in the category 'Innovative Steel Products' with the self-tapping concrete screw.
- 2005**  **First ETA approval is granted**
TOGE receives the first ETA approval for its own concrete screw in sizes 8 - 14, thus offering even greater safety.
- 2014**  **TOGE becomes part of the Würth Group**
As a consistent step towards the future and innovation, we have been part of the Würth Group and a strong network since 2014.
- 2021**  **Expansion of the company building**
TOGE is building a new administration building, a new production hall and a dedicated dowel laboratory for our Research & Development department.
- 2022**  **New corporate design and new website**
As part of the website relaunch, TOGE's brand identity is also being fundamentally revised and modernised. From now on, the core competence - The Fastening Experts - will be integrated into the logo as a claim. The new website also includes a virtual showroom.
- 2022**  **New premises for research & development**
Our research and development department will have a second home at the Reinhold Würth Innovation Centre CURIO in Künzelsau. As part of a 250-strong team, TOGE is working here on the future of fastening technology.

06 TOGE TSM PB

TOGE TSM PB

Aerated concrete screw for easy installation – even without pre-drilling



Fast and easy installation

Installation possible with and also without pre-drilling.



High service loads

High recommended loads for various aerated concrete strengths.

Base Material

✓ Aerated concrete.





Scan the QR code and go directly to the product page

For example, to view the approvals in detail you only need one click. Feel free to try it out!

06 TOGE TSM PB

HEADSHAPES AND MATERIALS

		Steel zinc-plated	Steel, zinc flake-coated	Stainless steel A4
	hexagonal head and pressed on washer	✓		
	countersunk head and multipoint drive	✓		
	panhead and multipoint drive	✓		

Application examples



Fastening wall cabinets

06 TOGE TSM PB

STEEL – ZINC PLATED

Version with hexagonal head and pressed on washer



Size
10

Washer-Ø
16,0 mm

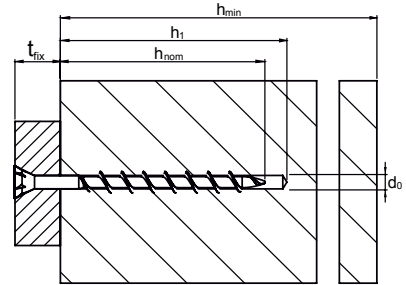

Item nr.	Designation	Embedment depth of anchor h_{nom}	Max. thickness of fixture t_{fix}	Packing Unit
230 101 102	TSM PB 10x110 SW10	100 mm	10 mm	100
230 101 602	TSM PB 10x160 SW10	100 mm	60 mm	100

Version with countersunk head and multipoint drive



Size
8
10

Head-Ø
12,0 mm
14,0 mm

Item nr.	Designation	Embedment depth of anchor h_{nom}	Max. thickness of fixture t_{fix}	Packing Unit
230 081 100	TSM PB 8x110 SeKo VZ25	80 mm	30 mm	100
230 101 100	TSM PB 10x110 SeKo VZ30	100 mm	10 mm	100
230 101 600	TSM PB 10x160 SeKo VZ30	100 mm	60 mm	100

06 TOGE TSM PB

STEEL – ZINC PLATED

Version with panhead and multipoint drive



Size
8

Head-Ø
12,0 mm

Item nr.	Designation	Embedment depth of anchor h_{nom}	Max. thickness of fixture t_{fix}	Packing Unit
230 080 801	TSM PB 8x80 LiKo VZ30	80 mm	–	100
230 081 001	TSM PB 8x100 LiKo VZ30	80 mm	20 mm	100



**Do you need support?
We will be happy to advise you!**

Call us: +49 911 659 68-43



06 TOGE TSM PB

TECHNICAL CHARACTERISTICS

Single fastening without fire exposure, Steel

Screw size TSM PB			8	10
Nominal diameter of drill bit	d_0	[mm]	0/4	0/4
Depth of drill hole	$\geq h_1$	[mm]	0/40	0/50
Nominal embedment depth	$\geq h_{nom}$	[mm]	80	100
Recommended load for PP2 -0,50 ²⁾	F_{empft}	[kN]	0,34	0,47
Recommended load for PP4 -0,65 ²⁾	F_{empft}	[kN]	0,68	0,92
Recommended load for PP6 -0,80 ²⁾	F_{empft}	[kN]	0,99	x
Recommended load for PP3,3 -0,60 ²⁾	F_{empft}	[kN]	x	0,94
Recommended load for PP4,4 -0,70 ²⁾	F_{empft}	[kN]	x	0,90
Diameter of clearing hole in the fixture	d	[mm]	9,0	10,0
Installation torque	T_{inst}	[Nm]	8	12

¹⁾ To determine the permissible load, the partial safety factor from the approval $\gamma_M = 1.0$ was taken into account on the resistance side and a partial safety factor $\gamma_F = 1.4$ on the action side. a partial safety factor $\gamma_F = 1.4$ was taken into account.

²⁾ These values apply without influence of the spacing and edge distances.



Private Label – our service for retailers

We offer a wide range of packaging solutions to our customers: Whether in TOGE presentation or adapted to your own individual design.

SIDE NOTE

06 TOGE TSM PB

INSTALLATION INSTRUCTIONS

Direct installation **Installation with pre-drilling**

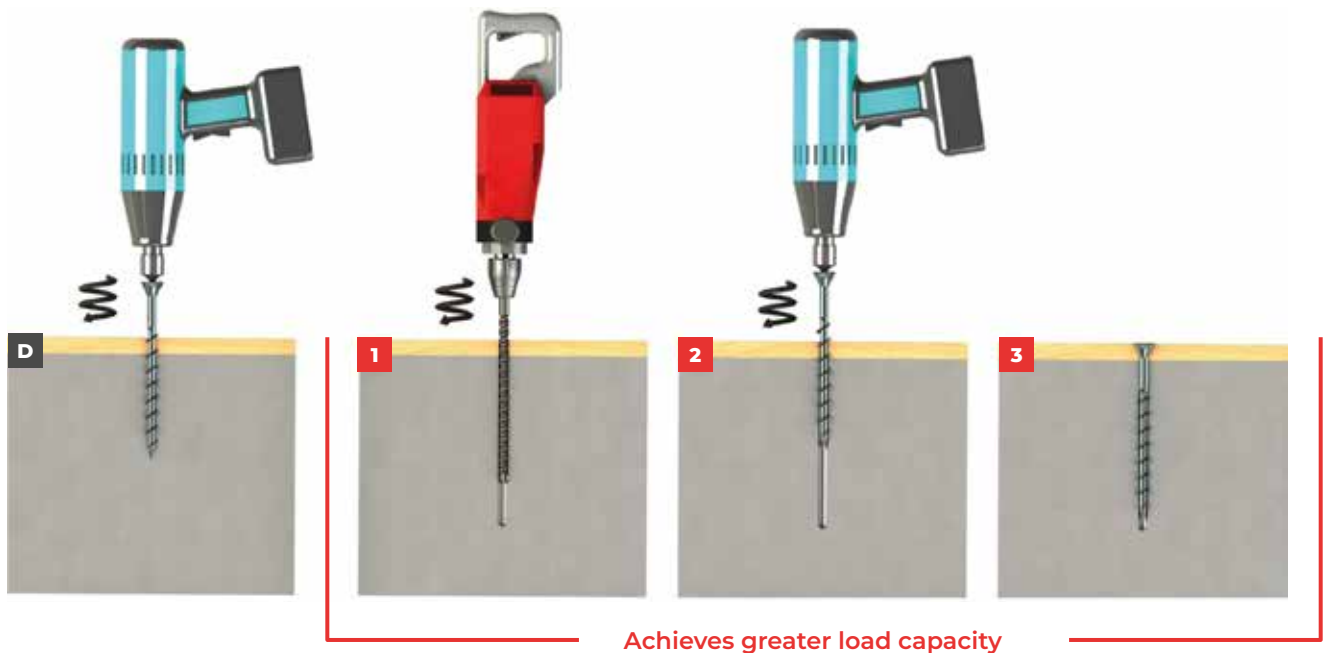

- D** Screw in without predrilling.
- 1** Create borehole.
- 2** Screw in the screw.
- 3** The screw head must rest completely on the attachment part.

07 TOGE TIS

TOGE TIS

Insulating screw for cold-, heat- and fire-protection



Cover Cap

Cover caps with textured structure made of polyethylene in three different colors for a coherent look of the entire surface.



Fast Installation

The small drilling diameter of only 6 mm allows fast, uncomplicated installation.



Variable load handling

Two different embedment depths of 25 mm or 35 mm allow variable load bearing for different panel thicknesses.



Easy Installation

The patented thread allows quick and easy installation with a standard cordless screwdriver without special tools. The TOGE TIS can be removed just as easily without leaving any residue.



No more reinforcement hits

The low embedment depths of 25 mm and 35 mm allow particularly userfriendly processing completely WITHOUT reinforcement hits.



Maximum thickness

Screw lengths up to 325 mm enable the fastening of insulating panels up to a thickness of 300 mm.



Fire protection

A fixed metal plate under the plastic cap ensures fire protection up to fire resistance class R120.



Easily adjustable

The screw thread allows adjustment of the insulation panels at any time during or after installation. For an even installation pattern over the entire surface.

Approval



- ✓ European technical assessment ETA-20/0779.
- ✓ General technical approval Z-21.8.1971.

Base Materials

- ✓ Approval for concrete strength classes from C20/25 to C50/60.
- ✓ Cracked and non-cracked concrete.
- ✓ TIS KORR coated for use in corrosivity categorie C3.







Scan the QR code and go directly to the product page

For example, to view the approvals in detail you only need one click. Feel free to try it out!

07 TOGE TIS

HEADSHAPES AND MATERIALS

		Steel zinc-plated	Steel, zinc flake-coated	Stainless steel A4
	Cover cap white	<input checked="" type="checkbox"/>	<input checked="" type="checkbox"/>	
	Cover cap BEIGE	<input checked="" type="checkbox"/>	<input checked="" type="checkbox"/>	
	Cover cap grey	<input checked="" type="checkbox"/>	<input checked="" type="checkbox"/>	
	Additional disc Ø 80 mm	<input checked="" type="checkbox"/>		

Application examples



07 TOGE TIS

STEEL – ZINC PLATED

Version with cover cap made of polyethylene Ø37 mm in white



Size
6

Head-Ø
37,0 mm

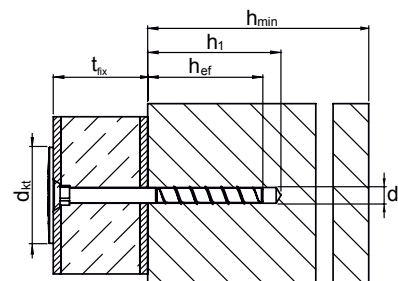

Item nr.	Designation	Depth of drill hole $h_{1,1} / h_{1,2}$	Embedment depth of anchor $h_{nom,1} / h_{nom,2}$	Max. thickness of fixture $t_{fix,1} / t_{fix,2}$	Packing Unit
031 169 050	TIS 50 WHITE	28 mm / 38 mm	25 mm / 35 mm	25 mm / 15 mm	100
031 169 075	TIS 75 WHITE	28 mm / 38 mm	25 mm / 35 mm	50 mm / 40 mm	100
031 169 085	TIS 85 WHITE	28 mm / 38 mm	25 mm / 35 mm	60 mm / 50 mm	100
031 169 100	TIS 100 WHITE	28 mm / 38 mm	25 mm / 35 mm	75 mm / 65 mm	100
031 169 110	TIS 110 WHITE	28 mm / 38 mm	25 mm / 35 mm	85 mm / 75 mm	100
031 169 125	TIS 125 WHITE	28 mm / 38 mm	25 mm / 35 mm	100 mm / 90 mm	100
031 169 135	TIS 135 WHITE	28 mm / 38 mm	25 mm / 35 mm	110 mm / 100 mm	100
031 169 150	TIS 150 WHITE	28 mm / 38 mm	25 mm / 35 mm	125 mm / 115 mm	100
031 169 175	TIS 175 WHITE	28 mm / 38 mm	25 mm / 35 mm	150 mm / 140 mm	100
031 169 200	TIS 200 WHITE	28 mm / 38 mm	25 mm / 35 mm	175 mm / 165 mm	100
031 169 225	TIS 225 WHITE	28 mm / 38 mm	25 mm / 35 mm	200 mm / 190 mm	100
031 169 250	TIS 250 WHITE	28 mm / 38 mm	25 mm / 35 mm	225 mm / 215 mm	100
031 169 275	TIS 275 WHITE	28 mm / 38 mm	25 mm / 35 mm	250 mm / 240 mm	100
031 169 300	TIS 300 WHITE	28 mm / 38 mm	25 mm / 35 mm	275 mm / 265 mm	100
031 169 325	TIS 325 WHITE	28 mm / 38 mm	25 mm / 35 mm	300 mm / 290 mm	100

Additional disc without marking
Ø 80 mm



Item nr.	Designation	Diameter	Packing Unit
030 158	TIS Disc 80	80 mm	250

07 TOGE TIS

STEEL – ZINC PLATED

Version with cover cap made of polyethylene Ø37 mm in beige



Size
6

Head-Ø
37,0 mm

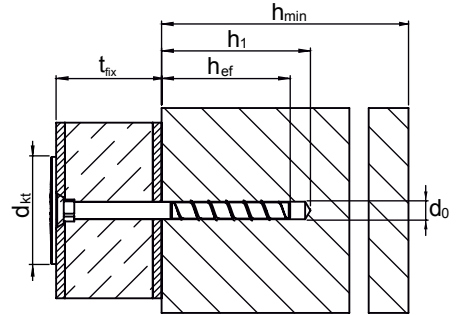

Item nr.	Designation	Depth of drill hole $h_{1,1} / h_{1,2}$	Embedment depth of anchor $h_{nom,1} / h_{nom,2}$	Max. thickness of fixture $t_{fix,1} / t_{fix,2}$	Packing Unit
031 269 050	TIS 50 BEIGE	28 mm / 38 mm	25 mm / 35 mm	25 mm / 15 mm	100
031 269 075	TIS 75 BEIGE	28 mm / 38 mm	25 mm / 35 mm	50 mm / 40 mm	100
031 269 085	TIS 85 BEIGE	28 mm / 38 mm	25 mm / 35 mm	60 mm / 50 mm	100
031 269 100	TIS 100 BEIGE	28 mm / 38 mm	25 mm / 35 mm	75 mm / 65 mm	100
031 269 110	TIS 110 BEIGE	28 mm / 38 mm	25 mm / 35 mm	85 mm / 75 mm	100
031 269 125	TIS 125 BEIGE	28 mm / 38 mm	25 mm / 35 mm	100 mm / 90 mm	100
031 269 135	TIS 135 BEIGE	28 mm / 38 mm	25 mm / 35 mm	110 mm / 100 mm	100
031 269 150	TIS 150 BEIGE	28 mm / 38 mm	25 mm / 35 mm	125 mm / 115 mm	100
031 269 175	TIS 175 BEIGE	28 mm / 38 mm	25 mm / 35 mm	150 mm / 140 mm	100
031 269 200	TIS 200 BEIGE	28 mm / 38 mm	25 mm / 35 mm	175 mm / 165 mm	100
031 269 225	TIS 225 BEIGE	28 mm / 38 mm	25 mm / 35 mm	200 mm / 190 mm	100
031 269 250	TIS 250 BEIGE	28 mm / 38 mm	25 mm / 35 mm	225 mm / 215 mm	100
031 269 275	TIS 275 BEIGE	28 mm / 38 mm	25 mm / 35 mm	250 mm / 240 mm	100
031 269 300	TIS 300 BEIGE	28 mm / 38 mm	25 mm / 35 mm	275 mm / 265 mm	100
031 269 325	TIS 325 BEIGE	28 mm / 38 mm	25 mm / 35 mm	300 mm / 290 mm	100

07 TOGE TIS

STEEL – ZINC PLATED

Version with cover cap made of polyethylene Ø37 mm in grey



Size
6

Head-Ø
37,0 mm

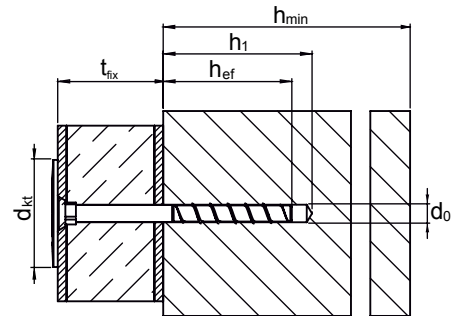

Item nr.	Designation	Depth of drill hole h_{i1} / h_{i2}	Embedment depth of anchor $h_{nom,1} / h_{nom,2}$	Max. thickness of fixture $t_{fix,1} / t_{fix,2}$	Packing Unit
031 069 050	TIS 50 GREY	28 mm / 38 mm	25 mm / 35 mm	25 mm / 15 mm	100
031 069 075	TIS 75 GREY	28 mm / 38 mm	25 mm / 35 mm	50 mm / 40 mm	100
031 069 085	TIS 85 GREY	28 mm / 38 mm	25 mm / 35 mm	60 mm / 50 mm	100
031 069 100	TIS 100 GREY	28 mm / 38 mm	25 mm / 35 mm	75 mm / 65 mm	100
031 069 110	TIS 110 GREY	28 mm / 38 mm	25 mm / 35 mm	85 mm / 75 mm	100
031 069 125	TIS 125 GREY	28 mm / 38 mm	25 mm / 35 mm	100 mm / 90 mm	100
031 069 135	TIS 135 GREY	28 mm / 38 mm	25 mm / 35 mm	110 mm / 100 mm	100
031 069 150	TIS 150 GREY	28 mm / 38 mm	25 mm / 35 mm	125 mm / 115 mm	100
031 069 175	TIS 175 GREY	28 mm / 38 mm	25 mm / 35 mm	150 mm / 140 mm	100
031 069 200	TIS 200 GREY	28 mm / 38 mm	25 mm / 35 mm	175 mm / 165 mm	100
031 069 225	TIS 225 GREY	28 mm / 38 mm	25 mm / 35 mm	200 mm / 190 mm	100
031 069 250	TIS 250 GREY	28 mm / 38 mm	25 mm / 35 mm	225 mm / 215 mm	100
031 069 275	TIS 275 GREY	28 mm / 38 mm	25 mm / 35 mm	250 mm / 240 mm	100
031 069 300	TIS 300 GREY	28 mm / 38 mm	25 mm / 35 mm	275 mm / 265 mm	100
031 069 325	TIS 325 GREY	28 mm / 38 mm	25 mm / 35 mm	300 mm / 290 mm	100

07 TOGE TIS

TOGE-KORR: STEEL – ZINC-FLAKE COATED

Version with cover cap made of polyethylene Ø37 mm in white



Size
6

Head-Ø
37,0 mm

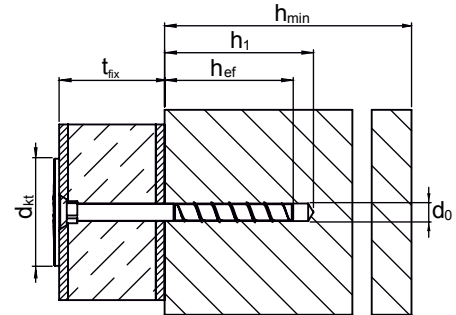

Item nr.	Designation	Depth of drill hole $h_{1,1} / h_{1,2}$	Embedment depth of anchor $h_{nom,1} / h_{nom,2}$	Max. thickness of fixture $t_{fix,1} / t_{fix,2}$	Packing Unit
031 168 050	TIS KORR 50 WHITE	28 mm / 38 mm	25 mm / 35 mm	25 mm / 15 mm	100
031 168 075	TIS KORR 75 WHITE	28 mm / 38 mm	25 mm / 35 mm	50 mm / 40 mm	100
031 168 085	TIS KORR 85 WHITE	28 mm / 38 mm	25 mm / 35 mm	60 mm / 50 mm	100
031 168 100	TIS KORR 100 WHITE	28 mm / 38 mm	25 mm / 35 mm	75 mm / 65 mm	100
031 168 125	TIS KORR 125 WHITE	28 mm / 38 mm	25 mm / 35 mm	100 mm / 90 mm	100
031 168 135	TIS KORR 135 WHITE	28 mm / 38 mm	25 mm / 35 mm	110 mm / 100 mm	100
031 168 150	TIS KORR 150 WHITE	28 mm / 38 mm	25 mm / 35 mm	125 mm / 115 mm	100
031 168 175	TIS KORR 175 WHITE	28 mm / 38 mm	25 mm / 35 mm	150 mm / 140 mm	100
031 168 200	TIS KORR 200 WHITE	28 mm / 38 mm	25 mm / 35 mm	175 mm / 165 mm	100
031 168 225	TIS KORR 225 WHITE	28 mm / 38 mm	25 mm / 35 mm	200 mm / 190 mm	100
031 168 250	TIS KORR 250 WHITE	28 mm / 38 mm	25 mm / 35 mm	225 mm / 215 mm	100
031 168 275	TIS KORR 275 WHITE	28 mm / 38 mm	25 mm / 35 mm	250 mm / 240 mm	100
031 168 300	TIS KORR 300 WHITE	28 mm / 38 mm	25 mm / 35 mm	275 mm / 265 mm	100
031 168 325	TIS KORR 325 WHITE	28 mm / 38 mm	25 mm / 35 mm	300 mm / 290 mm	100

07 TOGE TIS

TOGE-KORR: STEEL – ZINC-FLAKE COATED

Version with cover cap made of polyethylene Ø37 mm in beige



Size
6

Head-Ø
37,0 mm

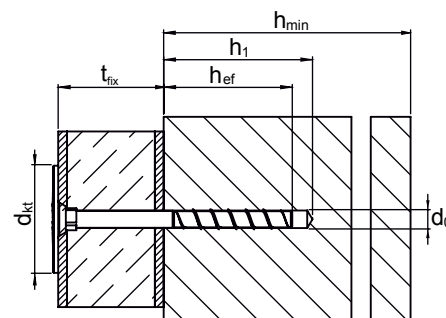

Item nr.	Designation	Depth of drill hole $h_{1,1} / h_{1,2}$	Embedment depth of anchor $h_{nom,1} / h_{nom,2}$	Max. thickness of fixture $t_{fix,1} / t_{fix,2}$	Packing Unit
031 268 050	TIS KORR 50 BEIGE	28 mm / 38 mm	25 mm / 35 mm	25 mm / 15 mm	100
031 268 075	TIS KORR 75 BEIGE	28 mm / 38 mm	25 mm / 35 mm	50 mm / 40 mm	100
031 268 085	TIS KORR 85 BEIGE	28 mm / 38 mm	25 mm / 35 mm	60 mm / 50 mm	100
031 268 100	TIS KORR 100 BEIGE	28 mm / 38 mm	25 mm / 35 mm	75 mm / 65 mm	100
031 268 125	TIS KORR 125 BEIGE	28 mm / 38 mm	25 mm / 35 mm	100 mm / 90 mm	100
031 268 135	TIS KORR 135 BEIGE	28 mm / 38 mm	25 mm / 35 mm	110 mm / 100 mm	100
031 268 150	TIS KORR 150 BEIGE	28 mm / 38 mm	25 mm / 35 mm	125 mm / 115 mm	100
031 268 175	TIS KORR 175 BEIGE	28 mm / 38 mm	25 mm / 35 mm	150 mm / 140 mm	100
031 268 200	TIS KORR 200 BEIGE	28 mm / 38 mm	25 mm / 35 mm	175 mm / 165 mm	100
031 268 225	TIS KORR 225 BEIGE	28 mm / 38 mm	25 mm / 35 mm	200 mm / 190 mm	100
031 268 250	TIS KORR 250 BEIGE	28 mm / 38 mm	25 mm / 35 mm	225 mm / 215 mm	100
031 268 275	TIS KORR 275 BEIGE	28 mm / 38 mm	25 mm / 35 mm	250 mm / 240 mm	100
031 268 300	TIS KORR 300 BEIGE	28 mm / 38 mm	25 mm / 35 mm	275 mm / 265 mm	100
031 268 325	TIS KORR 325 BEIGE	28 mm / 38 mm	25 mm / 35 mm	300 mm / 290 mm	100

07 TOGE TIS

TOGE-KORR: STEEL – ZINC-FLAKE COATED

Version with cover cap made of polyethylene Ø37 mm in grey



Size
6

Head-Ø
37,0 mm

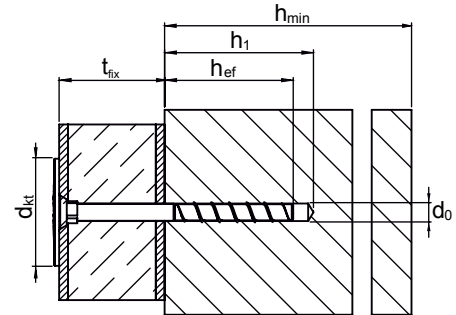

Item nr.	Designation	Depth of drill hole $h_{1,1} / h_{1,2}$	Embedment depth of anchor $h_{nom,1} / h_{nom,2}$	Max. thickness of fixture $t_{fix,1} / t_{fix,2}$	Packing Unit
031 068 050	TIS KORR 50 GREY	28 mm / 38 mm	25 mm / 35 mm	25 mm / 15 mm	100
031 068 075	TIS KORR 75 GREY	28 mm / 38 mm	25 mm / 35 mm	50 mm / 40 mm	100
031 068 085	TIS KORR 85 GREY	28 mm / 38 mm	25 mm / 35 mm	60 mm / 50 mm	100
031 068 100	TIS KORR 100 GREY	28 mm / 38 mm	25 mm / 35 mm	75 mm / 65 mm	100
031 068 125	TIS KORR 125 GREY	28 mm / 38 mm	25 mm / 35 mm	100 mm / 90 mm	100
031 068 135	TIS KORR 135 GREY	28 mm / 38 mm	25 mm / 35 mm	110 mm / 100 mm	100
031 068 150	TIS KORR 150 GREY	28 mm / 38 mm	25 mm / 35 mm	125 mm / 115 mm	100
031 068 175	TIS KORR 175 GREY	28 mm / 38 mm	25 mm / 35 mm	150 mm / 140 mm	100
031 068 200	TIS KORR 200 GREY	28 mm / 38 mm	25 mm / 35 mm	175 mm / 165 mm	100
031 068 225	TIS KORR 225 GREY	28 mm / 38 mm	25 mm / 35 mm	200 mm / 190 mm	100
031 068 250	TIS KORR 250 GREY	28 mm / 38 mm	25 mm / 35 mm	225 mm / 215 mm	100
031 068 275	TIS KORR 275 GREY	28 mm / 38 mm	25 mm / 35 mm	250 mm / 240 mm	100
031 068 300	TIS KORR 300 GREY	28 mm / 38 mm	25 mm / 35 mm	275 mm / 265 mm	100
031 068 325	TIS KORR 325 GREY	28 mm / 38 mm	25 mm / 35 mm	300 mm / 290 mm	100

07 TOGE TIS

TECHNICAL CHARACTERISTICS

Without fire exposure for multiple fastening TIS according ETA-20/0779

Screw size TIS			6	
Nominal embedment depth	h _{nom}	[mm]	h _{nom,1} ¹⁾	h _{nom,2}
			25	35
Nominal diameter of drill bit	d ₀	[mm]	6	
Depth of drill hole	h _{i min}	[mm]	28	38
Effective anchorage depth	h _{ef}	[mm]	19	27
Diameter of clearance hole in the fixture	d _{f max}	[mm]	8	
Permissible tension load in cracked concrete ^{2) 3)}	N _{zul}	[kN]	0,4	1,0
Permissible shear load in cracked concrete ^{2) 3)}	V _{zul}	[kN]	1,4	2,3
Permissible tension load in uncracked concrete ^{2) 3)}	N _{zul}	[kN]	1,0	1,9
Permissible shear load in uncracked concrete ^{2) 3)}	V _{zul}	[kN]	1,9	3,3
Permissible bending moment	M _{zul}	[kN]	6,3	
Minimum edge distance	C _{min}	[mm]	30	
Minimum spacing	S _{min}	[mm]	30	
Minimum Basements thickness	h _{min}	[mm]	80	

TIS according Z-21.8-1971

Screw size TIS			6	
Nominal embedment depth	h _{nom}	[mm]	h _{nom,1}	h _{nom,2}
			25	35
Nominal diameter of drill bit	d ₀	[mm]	6	
Depth of drill hole	h _{i min}	[mm]	28	38
Diameter of clearance hole in the fixture	d _{f max}	[mm]	8	
Approved load in all directions in cracked concrete ^{3) 4)}	F _{zul}	[kN]	0,4	1,0
Minimum edge distance	C _{min}	[mm]	30	
Minimum spacing	S _{min}	[mm]	30	
Minimum base material thickness	h _{min}	[mm]	80	

¹⁾ Only for use in dry conditions

²⁾ The partial safety factor for material resistance from the approval $\gamma_M = 1,5$ as well a partial safety factor for load actions $\gamma_F = 1,4$ were considered for determining the load.

³⁾ These values apply without influence of the spacing and edge distances.

⁴⁾ The partial safety factor for load actions $\gamma_F = 1,35$ was considered for determining the load.

07 TOGE TIS

TECHNICAL CHARACTERISTICS

Under fire exposure for multiple fastening TIS according ETA-20/0779

Screw size TIS		6				
Nominal embedment depth		h _{nom} [mm]	h _{nom,1} ¹⁾		h _{nom,2}	
			25		35	
Approved load under tensile and shear use (F _{zul,fi} = N _{zul,fi} = V _{zul,fi})						
Fire resistance class						
R 30	Approved load ²⁾	F _{zul,fi 30}	[kN]	0,23	0,27	
R 60		F _{zul,fi 60}	[kN]	0,23	0,27	
R 90		F _{zul,fi 90}	[kN]	0,22		
R 120		F _{zul,fi 120}	[kN]	0,17		
R 30		M _{zul,fi 30}	[Nm]	0,22		
R 60		M _{zul,fi 60}	[Nm]	0,22		
R 90		M _{zul,fi 90}	[Nm]	0,18		
R 120		M _{zul,fi 120}	[Nm]	0,14		
Edge distance						
R 30 bis R 120		C _{cr,fi}	[mm]	2 x h _{ef}		
The edge distance must be at least 300 mm if the fire load attacks from more than one side.						
Spacing						
R 30 bis R 120		S _{cr,fi}	[mm]	4 x h _{ef}		
Concrete pry-out failure						
R 30 bis R 120		k	[-]	1,0		
In wet concrete, the embedment depth must be increased by at least 30 mm.						

¹⁾ Only for use in dry conditions.

²⁾ The partial safety factor for material resistance from the approval γ_M = 1,5 as well a partial safety factor for load actions γ_F = 1,4 were considered for determining the load.

07 TOGE TIS

TECHNICAL CHARACTERISTICS

Under fire exposure for multiple fastening TIS according Z-21.8-1971

Screw size TIS				6	
Nominal embedment depth		h _{nom}	[mm]	h _{nom,1}	h _{nom,2}
				25	35
Approved load under tensile and shear use ($F_{zul,fi} = N_{zul,fi} = V_{zul,fi}$)					
Fire resistance class					
R 30	Approved load ²⁾	F _{zul,fi,30}	[kN]	0,27	
R 60		F _{zul,fi,60}	[kN]	0,27	
R 90		F _{zul,fi,90}	[kN]	0,22	
R 120		F _{zul,fi,120}	[kN]	0,17	
Edge distance					
R 30 bis R 120		C _{cr,fi}	[mm]	60	
The edge distance must be at least 300 mm if the fire load attacks from more than one side.					
Spacing					
R 30 bis R 120		S _{cr,fi}	[mm]	120	

²⁾ The partial safety factor for material resistance from the approval $\gamma_M = 1,5$ as well a partial safety factor for load actions $\gamma_F = 1,4$ were considered for determining the load.

07 TOGE TIS

INSTALLATION INSTRUCTIONS

Installation instructions

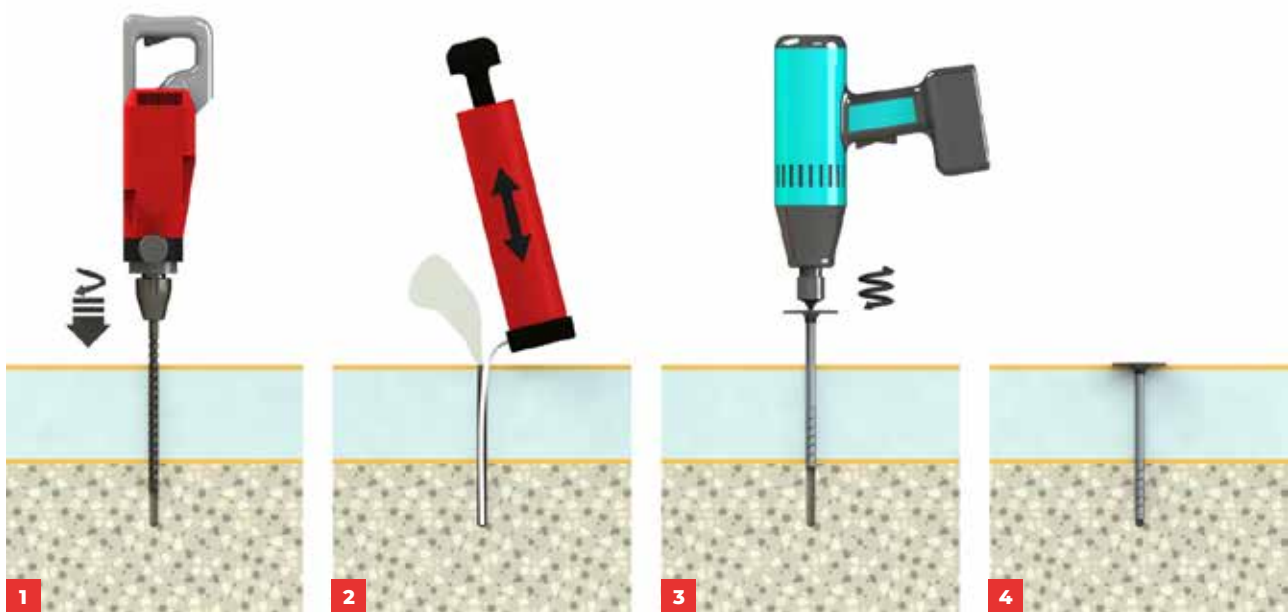

- 1 Create borehole.
- 2 Clean the borehole thoroughly.
- 3 Screw in the TOGE TIS with a standard cordless screwdriver – without special tools.
- 4 The screw head must rest completely on the attachment.



Our quality is and remains „Made in Germany“

All our products are in-house developments and are largely produced at our Nuremberg site.

SIDE NOTE

Discover now!

FASTENING SOLUTIONS FOR STRUCTURAL ENGINEERING

**Fastening of scaffolding
and formwork in the
renovation area**



**Bridge cap anchor DB Railway
(new cap construction or
existing caps)**



**Fastening of noise barriers
DB Railway**



**Bridge cap anchor road
bridges (new cap construction
or existing caps)**



Shear-Connector



**Fastening railings
and contact protection
DB Railway**



SELECT NOW



toge.de

08 TOGE TID

TOGE TID

The insulating anchor for cold-, heat- and fire-protection



Cover cap

Optional cover caps with textured structure made of polyethylene in different colors for a coherent look of the entire surface.



Corrosion resistance

The A2 stainless steel design provides optimum corrosion protection even in humid environments.



Fire protection

Fire protection up to fire resistance class R120.



Maximum thickness

Screw lengths up to 300 mm enable the fastening of insulating panels up to a thickness of 260 mm.

Approval



- ✓ General technical approval Z-21.8.1970.

Base Material

- ✓ Approval for concrete strength classes from C20/25 to C50/60.
- ✓ Cracked and non-cracked concrete.







Scan the QR code and go directly to the product page

For example, to view the approvals in detail you only need one click. Feel free to try it out!

08 TOGE TID

HEADSHAPES AND MATERIALS

		Steel zinc-plated	Steel, zinc flake-coated	Stainless steel A2
	Insulating anchor	✓		✓
	Insulating anchor with premounted large cap, white	✓		✓
	Cover caps in different colours, polyethylene			
	Additional disc without embossing Ø 80 mm	✓		
	Additional disc Ø 80 mm	✓		✓

Application examples

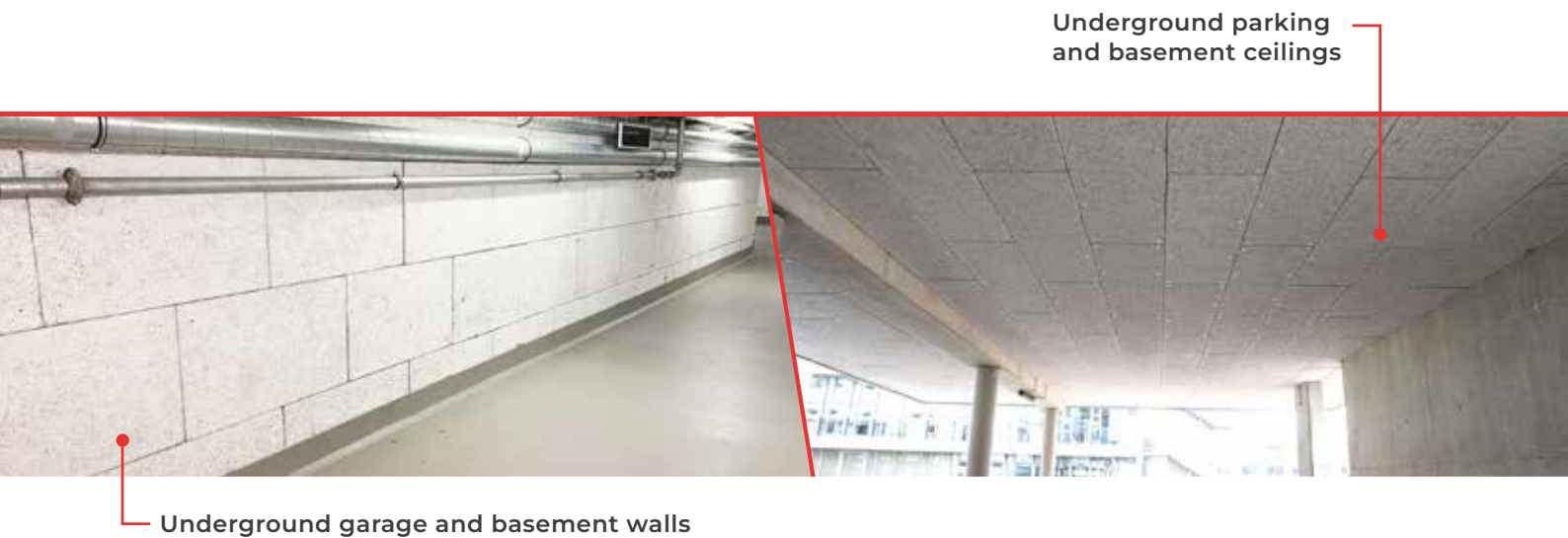

08 TOGE TID

STEEL – ZINC PLATED

Version without cover cap
Head Ø35 mm



Size
8

Head-Ø
35,0 mm

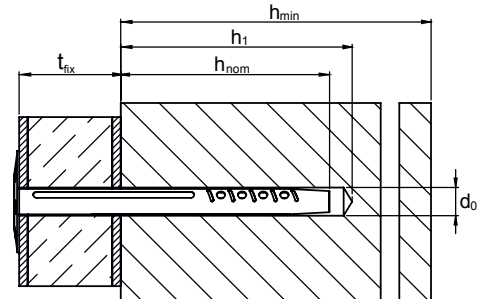

Item nr.	Designation	Depth of drill hole h_0	Embedment depth of anchor h_{nom}	Max. thickness of fixture t_{fix}	Packing Unit
031 061 050	TIDS 50	45 mm	40 mm	10 mm	500
031 061 080	TIDS 80	45 mm	40 mm	40 mm	250
031 061 110	TIDS 110	45 mm	40 mm	70 mm	250
031 061 120	TIDS 120	45 mm	40 mm	80 mm	250
031 061 140	TIDS 140	45 mm	40 mm	100 mm	250
031 061 170	TIDS 170	45 mm	40 mm	130 mm	250
031 061 200	TIDS 200	45 mm	40 mm	160 mm	250
031 061 250	TIDS 250	45 mm	40 mm	210 mm	200
031 061 300	TIDS 300	45 mm	40 mm	260 mm	200

Additional disc
Ø 80 mm



Item nr.	Designation	Diameter	Packing Unit
030 156	TIDS T	80 mm	250
030 158	TIDS T o. Pr.	80 mm	250

Cover caps Polyethylen,
various colours*

Item nr.	Designation	Diameter	Packing Unit
042 000 000	TID-E BEIGE	38 mm	250
042 000 100	TID-E WHITE	38 mm	250
042 000 200	TID-E GREY	38 mm	250



* other colours available upon request

08 TOGE TID

STEEL – ZINC PLATED

Version with premounted large cover cap in Polyethylen, white
Head Ø 54 mm



Size
8

Head-Ø
54,0 mm

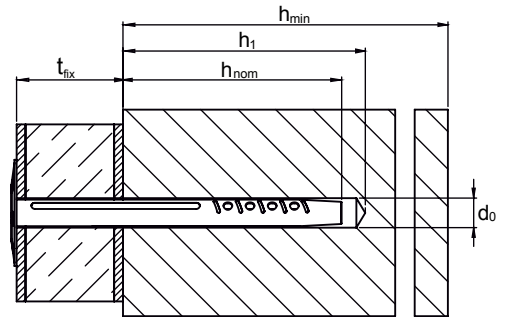

Item nr.	Designation	Depth of drill hole h_0	Embedment depth of anchor h_{nom}	Max. thickness of fixture t_{fix}	Packing Unit
031 361 080	TIDS-K 80	45 mm	40 mm	40 mm	250
031 361 110	TIDS-K 110	45 mm	40 mm	70 mm	250
031 361 140	TIDS-K 140	45 mm	40 mm	100 mm	250
031 361 170	TIDS-K 170	45 mm	40 mm	130 mm	250
031 361 200	TIDS-K 200	45 mm	40 mm	160 mm	250
031 361 250	TIDS-K 250	45 mm	40 mm	210 mm	200

Additional Disc
Ø 80 mm



Item nr.	Designation	Diameter	Packing Unit
030 156	TIDS T	80 mm	250
030 158	TIDS T o. Pr.	80 mm	250

08 TOGE TID

STAINLESS STEEL – A2

Version without cover cap

Head Ø35 mm



Size
8

Head-Ø
35,0 mm

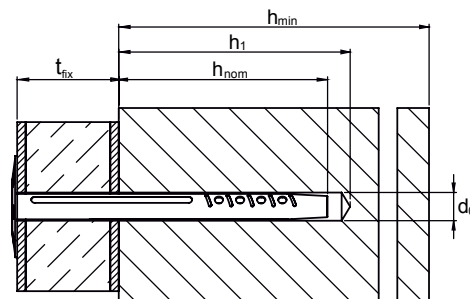

Item nr.	Designation	Depth of drill hole h_0	Embedment depth of anchor h_{nom}	Max. thickness of fixture t_{fix}	Packing Unit
031 063 050	TIDR 50	45 mm	40 mm	10 mm	500
031 063 080	TIDR 80	45 mm	40 mm	40 mm	250
031 063 110	TIDR 110	45 mm	40 mm	70 mm	250
031 063120	TIDR 120	45 mm	40 mm	80 mm	250
031 063 140	TIDR 140	45 mm	40 mm	100 mm	250
031 063 170	TIDR 170	45 mm	40 mm	130 mm	250
031 063 200	TIDR 200	45 mm	40 mm	160 mm	250
031 063 250	TIDR 250	45 mm	40 mm	210 mm	200
031 063 300	TIDR 300	45 mm	40 mm	260 mm	200

Additional disc
Ø 80 mm



Item nr.	Designation	Diameter	Packing Unit
030 157	TIDR T	80 mm	250

Cover caps Polyethylen,
various colours*

Item nr.	Designation	Diameter	Packing Unit
042 000 000	TID-E BEIGE	38 mm	250
042 000 100	TID-E WHITE	38 mm	250
042 000 200	TID-E GREY	38 mm	250



* other colours available upon request

08 TOGE TID

STAINLESS STEEL – A2

Version with premounted large cover cap in Polyethylen, white
Head Ø 54 mm



Size
8

Head-Ø
54,0 mm

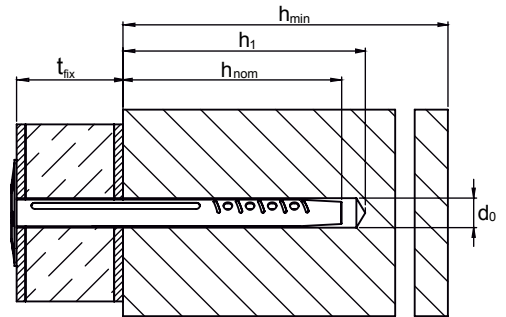

Item nr.	Designation	Depth of drill hole h_o	Embedment depth of anchor h_{nom}	Max. thickness of fixture t_{fix}	Packing Unit
031 363 080	TIDR-K 80	45 mm	40 mm	40 mm	250
031 363 110	TIDR-K 110	45 mm	40 mm	70 mm	250
031 363 140	TIDR-K 140	45 mm	40 mm	100 mm	250
031 363 170	TIDR-K 170	45 mm	40 mm	130 mm	250
031 363 200	TIDR-K 200	45 mm	40 mm	160 mm	250
031 363 250	TIDR-K 250	45 mm	40 mm	210 mm	200

Additional disc
Ø 80 mm



Item nr.	Designation	Diameter	Packing Unit
030 157	TIDR T	80 mm	250

08 TOGE TID

TECHNICAL CHARACTERISTICS

Without fire exposure for multiple fastening TID according Z-21.8-1970

Insulating anchor TID			
Nominal diameter of drill bit	d_0	[mm]	8
Depth of drill hole	$h_0 \geq$	[mm]	45
Embedment depth of anchor	$h_{nom} \geq$	[mm]	40
Approved load in cracked and non-cracked concrete ¹⁾	N_{zul}	[kN]	0,07
Minimum edge distance	c_{min}	[mm]	60
Minimum spacing	s_{min}	[mm]	120
Minimum base material thickness	h_{min}	[mm]	80

Under fire exposure for multiple fastening TID according Z-21.8-1970

Insulating anchor TID				
Approved load under tensile and shear use ($F_{zul,fi} = N_{zul,fi} = V_{zul,fi}$)				
Fire resistance class				
R 30	Approved load ²⁾	$F_{zul,fi,30}$	[kN]	0,07
R 60		$F_{zul,fi,60}$	[kN]	0,07
R 90		$F_{zul,fi,90}$	[kN]	0,07
R 120		$F_{zul,fi,120}$	[kN]	0,06
Edge distance				
R 30 bis R 120	$c_{cr,fi}$	[mm]	80	
The edge distance must be at least 300 mm if the fire load attacks from more than one side.				
Spacing				
R 30 bis R 120	$s_{cr,fi}$	[mm]	160	

¹⁾ The partial safety factor for material resistance from the approval $\gamma_M = 1,5$ as well a partial safety factor for load actions $\gamma_F = 1,4$ were considered for determining the load.

²⁾ The partial safety factor for material resistance from the approval $\gamma_M = 1,0$ as well a partial safety factor for load actions $\gamma_F = 1,0$ were considered for determining the load.

08 TOGE TID

INSTALLATION INSTRUCTIONS

Installation instructions

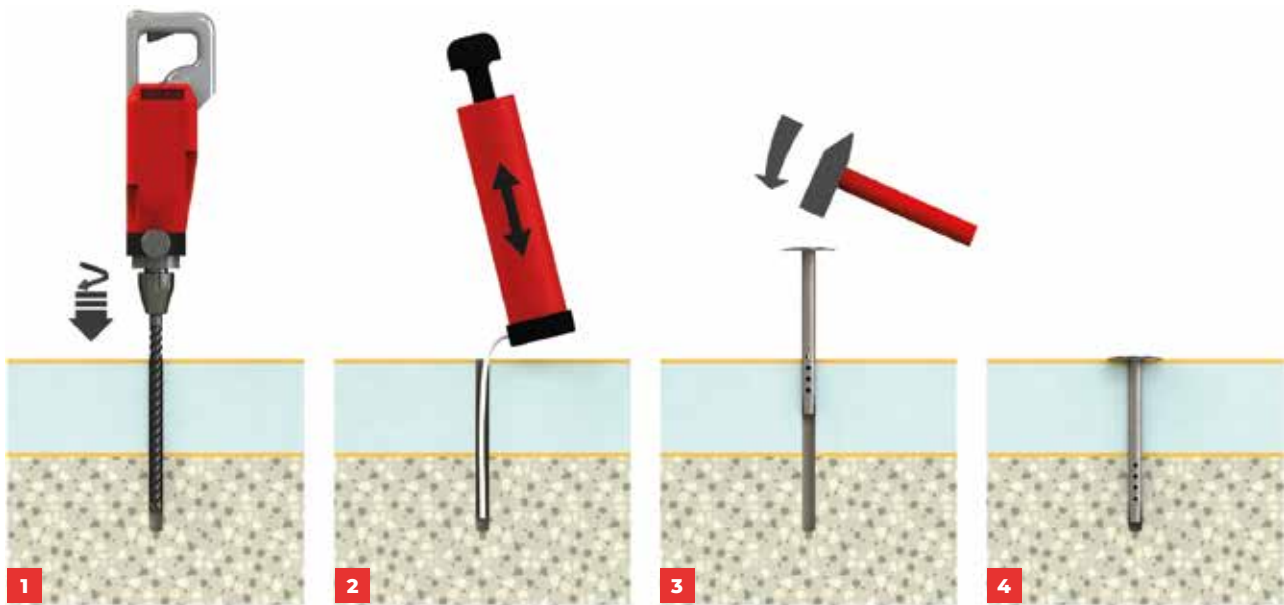

- 1 Create borehole.
- 2 Clean the borehole thoroughly.
- 3 Drive the insulating anchor through the insulating plate with a hammer.
- 4 The dowel plate must rest completely on the attachment part.



Short supply chains

Currently, 90% of our suppliers are located within a 500 km radius – for shorter delivery times and an improved environmental balance.

SIDE NOTE

Our fastening solutions

**MADE IN GERMANY:
COMPLETELY DESIGNED
AND MANUFACTURED
IN GERMANY**



**LEADING IN THE
DEVELOPMENT
OF CONCRETE
SCREWS**



**UNIQUE
PRODUCT RANGE
OF CONCRETE
SCREWS**



**60 YEARS
OF EXPERIENCE
AS FASTENING
EXPERTS**



**OUR
QUALITY:
MADE IN
GERMANY**

German precision and variety

We have been a leader in the development of concrete screws for over 30 years and are one of the pioneers in this field. As a specialised manufacturer, we offer a unique product range with over 600 different concrete screws. With 60 years of experience as fastening experts, we stand for experience, innovative spirit and reliability since 1964. Our quality is "Made in Germany": All our products are in-house developments and are largely produced at our site in Nuremberg.

TO WEBSITE

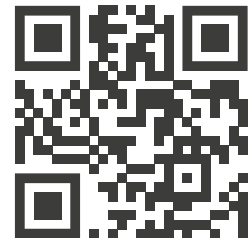

toge.de/en/

09 TOGE TSM A

TOGE TSM A

Asphalt screw for fastening directly into asphalt – without concrete foundation



Simple Fastening

Simple fastening directly into the asphalt – without additional concrete foundation.



Frost proof

Sealing the borehole prevents water penetration and frost damage in winter.



Flush with surface

Surface flush installation, also suitable for temporary installation.

Base Material

- ✓ Application in all common asphalt types.



Scan the QR code and go directly to the product page

For example, to view the approvals in detail you only need one click. Feel free to try it out!

09 TOGE TSM A

HEADSHAPES AND MATERIALS

Steel
zinc-plated

Steel,
anti-corrosion
coated

Stainless steel
A4

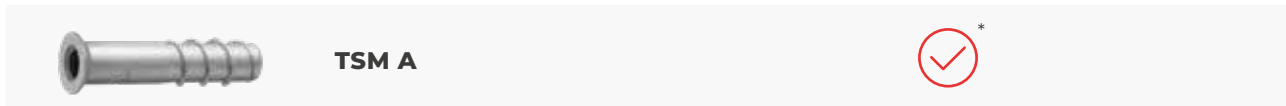

TSM A



Composite mortar
and accessories

* according to corrosivity
category C5-I agent with
premium coating
TOGE KORR

Application examples

Fastening of
e-charging points

Fastening passive restraint
systems and traffic signs



Fastening of impact
protection systems

Fastening of enclosures
for shopping trolleys

Fastening of
speed bumps

09 TOGE TSM A

STEEL – ANTI-CORROSION COATED

Version with female thread
IM 10 or IM 16

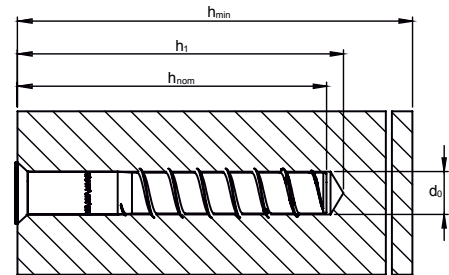

Item nr.	Designation	Bore Ø	Depth of drill hole h_o	Embedment depth of anchor h_{nom}	Packing Unit
202 161 001	TSM A 16x100 IM10 x 20 SW12 KORR	16 mm	110mm	100 mm	50
202 221 000	TSM A 22x100 IM16 x 30 SW12 KORR	22 mm	110 mm	100 mm	50
202 221 551	TSM A 22x155 IM16 x 30 SW12 KORR	22 mm	165 mm	155 mm	40
500 000 014	Reduzierstück M16/M12				25
500 000 015	Reduzierstück M16/M10				25
500 000 002	Einschraubwerkzeug SW12				1

COMPOSITE MORTAR ATA 2004C

Chemical special mortar
Pure epoxy, suitable for asphalt screws



Item nr.	Designation	Packing Unit
222 222 019	Cartridge for ATA 2004C, 585 ml	1
222 223 002	Mixing nozzle for ATA 2004C	1
222 222 014	Squeezing pistol for ATA 2004C, 585 ml	1

09 TOGE TSM A

COMPOSITE MORTAR ATA 2004C

Strokes ATA 2004C/
Depth of drill hole and \varnothing

● \varnothing 22
■ \varnothing 16

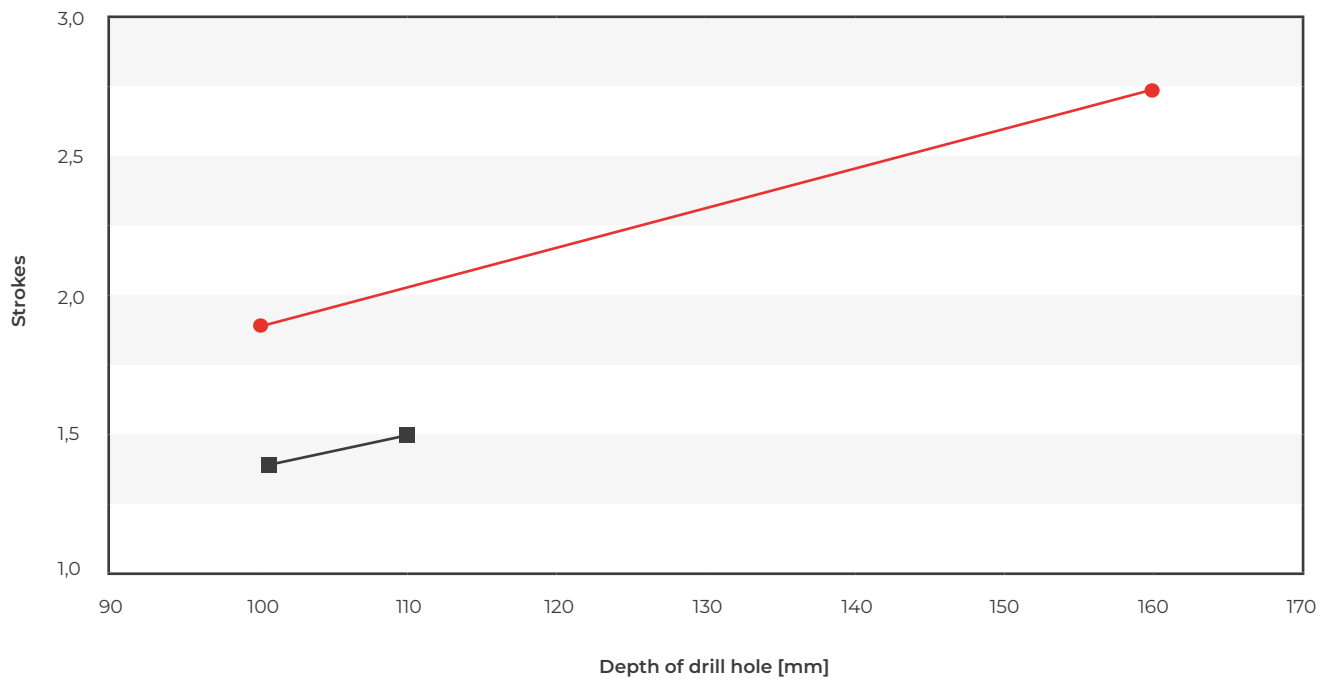

Cartridge coverage
ATA 2004C

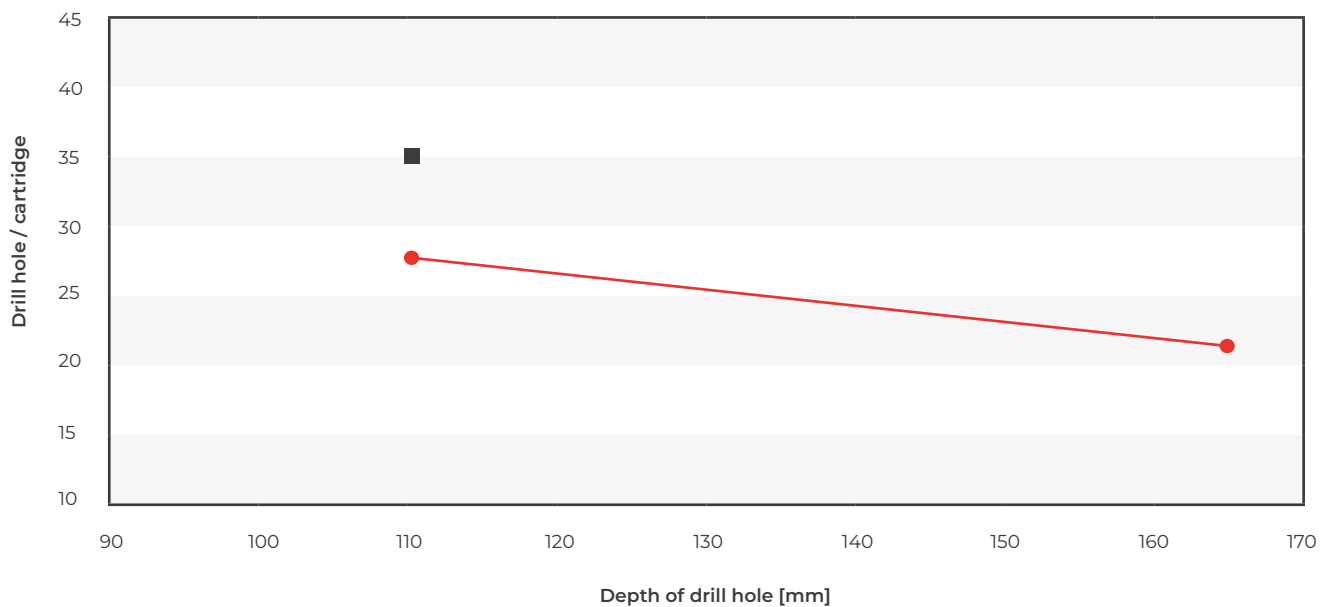

09 TOGE TSM A

COMPOSITE MORTAR ATA 2004C

Processing instructions
Composite mortar

Temperature in ground	Processing time	Min. curing time
0 °C	90 min	144 h
6 °C	80 min	48 h
10 °C	60 min	28 h
15 °C	40 min	18 h
20 °C	30 min	12 h
25 °C	12 min	9 h
35 °C	8 min	6 h
45 °C	8 min	4 h

TECHNICAL CHARACTERISTICS

Without fire exposure, Steel

Screw size TSM A			16 x 100	22 x 100	22 x 155
Nominal diameter of drill bit	d_0	[mm]	16	22	22
Depth of drill hole	h_1 min	[mm]	110	110	165
Minimum thickness of member	h_{min} \geq	[mm]	150	150	200
Nominal embedment depth	h_{nom}	[mm]	100	100	155
Fastening screw used			M 10 x 30	M 16 x 40	M 16 x 40
Strokes ATA 2004			1 to 2	1 to 2	2 to 3
Cartridge is sufficient			35	27	21
Maximum shock load	F	[kN]	40	50	80

09 TOGE TSM A

INSTALLATION INSTRUCTIONS

Installation instructions

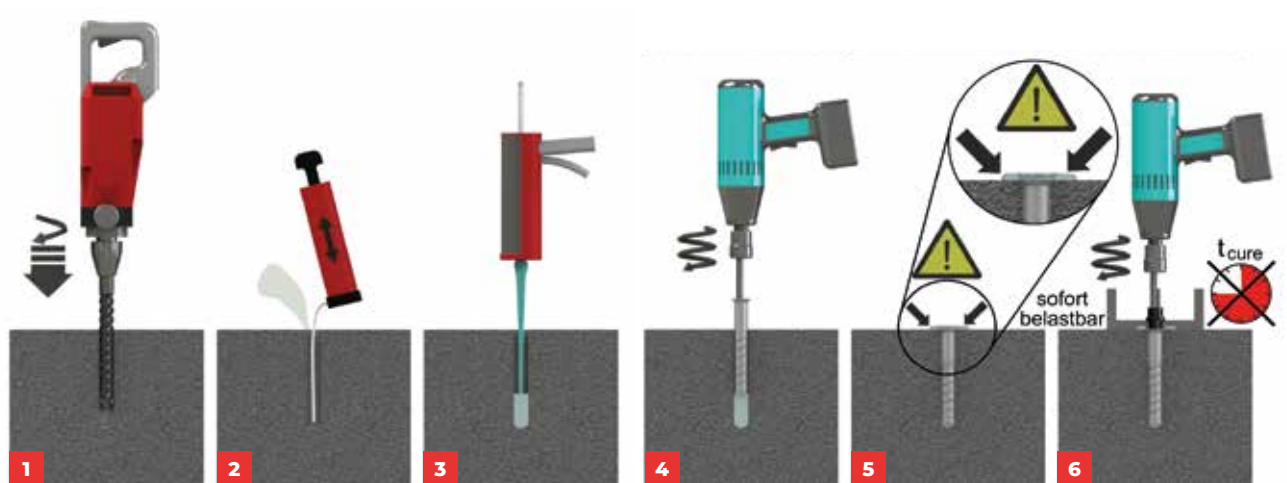

- 1** Create borehole.
- 2** Clean the borehole thoroughly.
- 3** Inject composite mortar.
- 4** Screw in the asphalt screw.
- 5** After reaching the screw-in depth, the composite mortar must emerge at the asphalt surface.
- 6** The attachment can be installed immediately – there is no need to observe the curing time of the composite mortar.

09 TOGE TSM A

INSTALLATION INSTRUCTIONS

Operating principle of anchoring



1. The 90°-Principle

The collar of the anchor is braced against the base plate at an angle of 90°. When torque is applied, the entire system is tilted, but this is prevented by the asphalt. Vertical extraction of the anchor from the substrate is not possible.



2. The Undercut

When the screw anchor is screwed in, a thread-shaped undercut is created in the substrate. This creates a positive fit between the substrate and the thread of the asphalt screw.

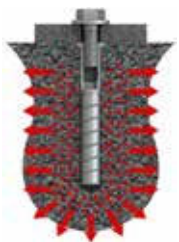

3. The chemical mortar

The air voids present in the asphalt are compressed by the final turning process of the TSM A as if by a hydraulic cylinder with the composite mortar. This results in a firmer and more homogeneous base in the force application area.



4. Preloaded free anchoring

The collar of the TSM A is larger than the clearance hole in the fixture to be connected. The base plate is clamped between the collar and the head of the fastening screw. This way the TSM A remains unencumbered.

09 TOGE TSM A

INSTALLATION INSTRUCTIONS

Operating principle of anchoring



5. Large surface

In the case of shock load, a limited excavation does not occur as in concrete. A much larger area is activated.

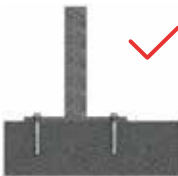

6. No overhanging loads

The anchoring system is not suitable for permanent tensile loading.

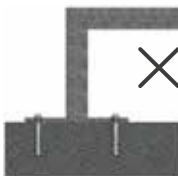

QUALITY
MADE
GERMANY **IN**

10 TOGE TSM Adhesive screw anchor

TOGE TSM ADHESIVE SCREW ANCHOR

Concrete screw in combination with injection mortar – for highest loads



Highest loads

Highest loads in concrete due to the combination of concrete screw with suitable injection mortar.



Frost proof

Sealing the borehole prevents water penetration and frost damage in winter.



Instantly loadable

Immediately loadable directly after installation.



High service load

Versatile due to variable anchoring depths.

Approval



- ✓ General type approval / General technical approval Z-21.1-2074.

Base Materials

- ✓ Application in cracked and non-cracked concrete of strength classes from C20/25 to C50/60.





Scan the QR code and go directly to the product page

For example, to view the approvals in detail you only need one click. Feel free to try it out!

10 TOGE TSM Adhesive screw anchor

HEADSHAPES AND MATERIALS

		Steel zinc-plated	Steel, zinc flake-coated	Stainless steel A4
	Hexagonal head pressed on washer	✓	✓	
	Metric connection thread M12	✓		✓
	Injection mortar and accessories			

Application examples

Fastening heavy duty shelving



Fastening railings

10 TOGE TSM Adhesive screw anchor

STEEL – ZINC PLATED

Version with hexagonal head and pressed on washer



Size	Washer-Ø
10	20,0 mm
12	23,5 mm
14	28,5 mm

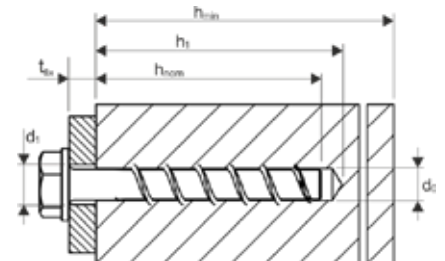

Item nr.	Designation	Depth of drill hole h_0	Embedment depth of anchor h_{nom}	Max. thickness of fixture t_{fix}	Packing Unit
300 010 090	TSM 10x90 SW15	≥ 80 mm	≥ 80 mm	10 mm	50
300 010 100	TSM 10x100 SW15	≥ 80 mm	≥ 80 mm	20 mm	50
300 010 120	TSM 10x120 SW15	≥ 80 mm	≥ 80 mm	40 mm	50
300 010 140	TSM 10x140 SW15	≥ 80 mm	≥ 80 mm	60 mm	50
300 010 150	TSM 10x150 SW15	≥ 80 mm	≥ 80 mm	70 mm	50
300 010 160	TSM 10x160 SW15	≥ 80 mm	≥ 80 mm	80 mm	50
300 010 180	TSM 10x180 SW15	≥ 80 mm	≥ 80 mm	100 mm	25
300 010 200	TSM 10x200 SW15	≥ 80 mm	≥ 80 mm	120 mm	25
300 010 240	TSM 10x240 SW15	≥ 80 mm	≥ 80 mm	160 mm	25
300 010 280	TSM 10x280 SW15	≥ 80 mm	≥ 80 mm	200 mm	25
300 010 320	TSM 10x320 SW15	≥ 80 mm	≥ 80 mm	240 mm	25
300 010 360	TSM 10x360 SW15	≥ 80 mm	≥ 80 mm	280 mm	25
300 010 400	TSM 10x400 SW15	≥ 80 mm	≥ 80 mm	320 mm	25
300 012 110	TSM 12x110 SW17	≥ 100 mm	≥ 100 mm	10 mm	25
300 012 130	TSM 12x130 SW17	≥ 100 mm	≥ 100 mm	30 mm	25
300 012 150	TSM 12x150 SW17	≥ 100 mm	≥ 100 mm	50 mm	25
300 014 130	TSM 14x130 SW21	≥ 100 mm	≥ 100 mm	30 mm	25
300 014 150	TSM 14x150 SW21	≥ 100 mm	≥ 100 mm	50 mm	25

10 TOGE TSM Adhesive screw anchor

STEEL – ZINC PLATED

Version with metric connection thread M12

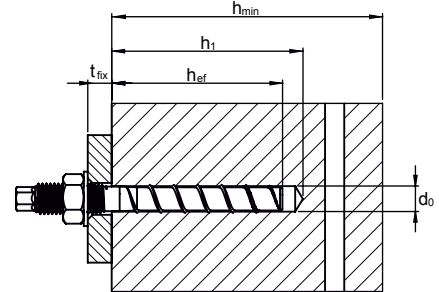

Item nr.	Designation	Depth of drill hole h_o	Embedment depth of anchor h_{ef}	Max. thickness of fixture t_{fix}	Packing Unit
366 010 120	TSM 10x120 M12x20 SW9	≥ 80 mm	≥ 80 mm	5 - 15 mm	50



Pioneers of Composite Anchor Technology

The steel and stainless steel concrete screws from TOGE have already had a system approval with significant load increases since 2002, which allows the use of the screw technology with composite adhesive with immediate load capacity (no curing times required).

SIDE NOTE

10 TOGE TSM Adhesive screw anchor

STEEL – ZINC FLAKE-COATED

Version with hexagon head
and pressed on washer



Size	Washer-Ø
10	20,0 mm
12	23,5 mm
14	28,5 mm

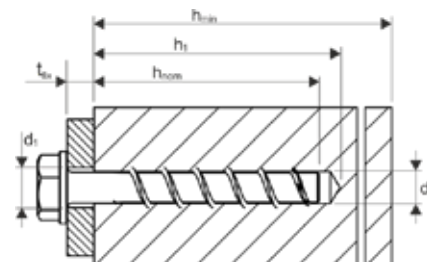

Item nr.	Designation	Depth of drill hole h_o	Embedment depth of anchor h_{nom}	Max. thickness of fixture t_{fix}	Packing Unit
400 010 090	TSM 10x90 SW15 ZFC	≥ 80 mm	≥ 80 mm	10 mm	50
400 010 100	TSM 10x100 SW15 ZFC	≥ 80 mm	≥ 80 mm	20 mm	50
400 010 120	TSM 10x120 SW15 ZFC	≥ 80 mm	≥ 80 mm	40 mm	50
400 010 140	TSM 10x140 SW15 ZFC	≥ 80 mm	≥ 80 mm	60 mm	50
400 010 150	TSM 10x150 SW15 ZFC	≥ 80 mm	≥ 80 mm	70 mm	50
400 010 160	TSM 10x160 SW15 ZFC	≥ 80 mm	≥ 80 mm	80 mm	50
400 010 180	TSM 10x180 SW15 ZFC	≥ 80 mm	≥ 80 mm	100 mm	25
400 010 200	TSM 10x200 SW15 ZFC	≥ 80 mm	≥ 80 mm	120 mm	25
400 010 240	TSM 10x240 SW15 ZFC	≥ 80 mm	≥ 80 mm	160 mm	25
400 010 280	TSM 10x280 SW15 ZFC	≥ 80 mm	≥ 80 mm	200 mm	25
400 010 320	TSM 10x320 SW15 ZFC	≥ 80 mm	≥ 80 mm	240 mm	25
400 010 360	TSM 10x360 SW15 ZFC	≥ 80 mm	≥ 80 mm	280 mm	25
400 010 400	TSM 10x400 SW15 ZFC	≥ 80 mm	≥ 80 mm	320 mm	25
400 012 110	TSM 12x110 SW17 ZFC	≥ 100 mm	≥ 100 mm	10 mm	25
400 012 130	TSM 12x130 SW17 ZFC	≥ 100 mm	≥ 100 mm	30 mm	25
400 012 150	TSM 12x150 SW17 ZFC	≥ 100 mm	≥ 100 mm	50 mm	25
400 014 130	TSM 14x130 SW21 ZFC	≥ 100 mm	≥ 100 mm	30 mm	25
400 014 150	TSM 14x150 SW21 ZFC	≥ 100 mm	≥ 100 mm	50 mm	25

10 TOGE TSM Adhesive screw anchor

STAINLESS STEEL – A4

Version with metric connection thread M12

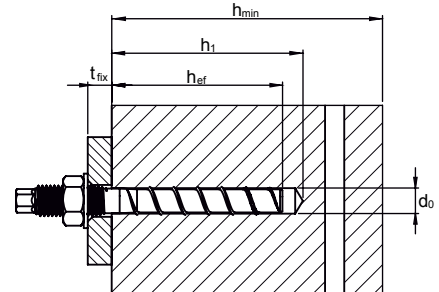

Item nr.	Designation	Depth of drill hole h_0	Embedment depth of anchor h_{nom}	Max. thickness of fixture t_{fix}	Packing Unit
866 010 140	TSM 10x140 M12x35 SW9 A4	≥ 80 mm	≥ 80 mm	5 - 34 mm	50
866 010 160	TSM 10x160 M12x55 SW9 A4	≥ 80 mm	≥ 80 mm	5 - 34 mm	50

COMPOSITE MORTAR CF-T 300V

Chemical special mortar, vinylester styrene-free, suitable for concrete screws



Item nr.	Designation	Packing Unit
222 222 003	Cartridge CF-T 300 V	1
222 223 001	Mixing nozzle for CF-T 300 V	1
222 222 004	Squeezing pistol for CF-T 300 V	1

10 TOGE TSM Adhesive screw anchor

COMPOSITE MORTAR CF-T 300V

Processing instructions
composite mortar

Temperature in ground	Processing time	Min. curing time in dry borehole	Min. curing time in wet borehole
≥ -5°C	60 min	360 min	720 min
≥ 0°C	60 min	180 min	360 min
≥ 5°C	60 min	120 min	240 min
≥ 10°C	45 min	80 min	160 min
≥ 20°C	15 min	45 min	90 min
≥ 30°C	5 min	25 min	50 min
≥ 35°C	4 min	20 min	40 min

Strokes & cartridge coverage
composite mortar

Depth of drill hole [mm]	Strokes / TSM screws Ø			Drills per cartridge / TSM screws Ø		
	10	12	14	10	12	14
80 - 90	0,8			44		
90 - 100	0,9			40		
100 - 110	1,0	1,1	1,3	37	32	28
110 - 120		1,2	1,4		30	26
120 - 130		1,3	1,5		27	24
130 - 140			1,6			22

10 TOGE TSM Adhesive screw anchor

TECHNICAL CHARACTERISTICS

Single fastening without fire exposure, TSM high performance according Z-21.1-2074

Screw size TSM high performance			TSM 10			TSM 12			TSM 14	
Nominal embedment depth	h_{ef} [mm]		$h_{ef,1}$	$h_{ef,2}$	$h_{ef,3}$	$h_{ef,1}$	$h_{ef,2}$	$h_{ef,3}$	$h_{ef,1}$	$h_{ef,2}$
			90	120	280	110	130	150	130	150
Nominal diameter of drill bit	d_o	[mm]	10			12			14	
Depth of drill hole	h_o min	[mm]	90	120	280	110	130	150	130	150
Effective anchorage depth	h_{ef}	[mm]	90	120	280	110	130	150	130	150
Diameter of clearance hole in the fixture	d_f max	[mm]	14			16			18	
Diameter of the brush	d_b max	[mm]	11			13			15	
Approved tension load in cracked concrete ^{1) 2)}	N_{zul}	[kN]	14,0	18,9	18,9	18,9	24,3	28,7	24,3	30,1
Approved shear load in cracked concrete ^{1) 2)}	V_{zul}	[kN]	19,4	19,4	19,4	24,0	24,0	24,0	32,0	32,0
Approved tension load in non-cracked concrete ^{1) 2)}	N_{zul}	[kN]	18,9	18,9	18,9	27,0	28,7	28,7	32,1	32,1
Approved shear load in non-cracked concrete ^{1) 2)}	V_{zul}	[kN]	19,4	19,4	19,4	24,0	24,0	24,0	32,0	32,0
Permissible bending moment	M_{zul}	[kN]	32,0			64,6			105,7	
Minimum edge distance	C_{min}	[mm]	40			50			60	
Minimum spacing	S_{min}	[mm]	40			50			60	
Minimum Basements thickness	h_{min}	[mm]	150	180	340	170	190	210	200	220
Installation torque (with metric connection thread)	T_{inst}	[Nm]	40			60			80	
Maximum torque (with impact screw driver)		[Nm]	400			650			650	

¹⁾ For the determination of the allowable load, the partial safety factor from the approval $\gamma_M = 1.4$ was taken into account for material resistance and a partial safety factor $\gamma_F = 1.4$ for load actions.

²⁾ These values apply without the influence of the spacing and edge distances.

10 TOGE TSM Adhesive screw anchor

TECHNICAL CHARACTERISTICS

Single fastening under fire exposure TSM high performance according Z-21.1-2074

Screw size TSM high performance		TSM 10			TSM 12			TSM 14		
Nominal embedment depth	h_{ef} [mm]	$h_{ef,1}$	$h_{ef,2}$	$h_{ef,3}$	$h_{ef,1}$	$h_{ef,2}$	$h_{ef,3}$	$h_{ef,1}$	$h_{ef,2}$	
		90	120	280	110	130	150	130	150	
Permissible load under tensile and shear use ($F_{zul} = N_{zul,fi} = V_{zul,fi}$)										
Fire resistance class										
R30	Approved load	$F_{zul, fi30}$ [kN]	4,4			6,2			7,6	
R60		$F_{zul, fi60}$ [kN]	3,3			5,8			7,6	
R90		$F_{zul, fi90}$ [kN]	2,3			4,2			5,9	
R120		$F_{zul, fi120}$ [kN]	1,7			3,4			4,8	
R30		$M_{zul, fi30}$ [kN]	5,9			12,3			20,4	
R60		$M_{zul, fi60}$ [kN]	4,5			9,7			15,9	
R90		$M_{zul, fi90}$ [kN]	3,0			7,0			11,6	
R120		$M_{zul, fi120}$ [kN]	2,3			5,7			9,4	
Edge distance										
R30 to R120		$C_{cr,fi}$ [mm]	$2 \times h_{ef}$							
The edge distance must be at least 300 mm if the fire load attacks from more than one side.										
Spacing										
R30 to R120	$S_{cr,fi}$ [mm]	$4 \times h_{ef}$								
Concrete pry-out failure										
R30 to R120	k [-]	2,0								
In wet concrete the embedment depth must be increased by at least 30 mm.										

¹⁾ For the determination of the allowable load, the partial safety factor from the approval $\gamma_M = 1.0$ was taken into account for material resistance and a partial safety factor $\gamma_F = 1.0$ for load actions.

10 TOGE TSM Adhesive screw anchor

INSTALLATION INSTRUCTIONS

Installation instructions

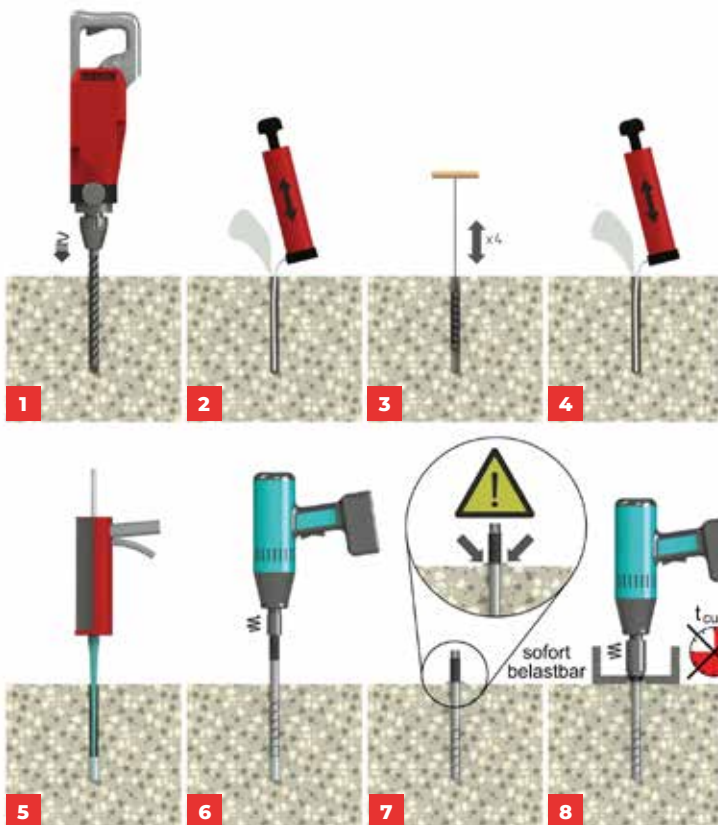

- 1 Create borehole.
- 2 Clean the borehole thoroughly.
- 3 Brush the borehole 4x.
- 4 Thoroughly clean the borehole again.
- 5 Discard three full strokes of composite mortar – then inject composite mortar.
- 6 Screw in concrete screw.
- 7 After reaching the embedment depth, the composite mortar must emerge at the concrete surface.
- 8 The attachment can be installed immediately – there is no need to observe the curing time of the composite mortar.

TOGE as a partner

FAIR AND RELIABLE: OUR SERVICES FOR YOU AS A DEALER OR DISTRIBUTOR



**PRIVATE LABEL
PACKAGING**



**TRANSFER
OF APPROVALS**



**DIMENSIONING
SERVICE AND
SOFTWARE**



**SALES
TRAININGS**



**MARKETING
MATERIAL**

GET IN TOUCH



toge.de/en/kontakt

11 TOGE TSM B

TOGE TSM B

Adhesive screw anchor
for fastening crash barriers



High loads

High load bearing capacity in cracked and non-cracked concrete.



Fast and safe installation

The optimized thread enables a quick and safe installation process.



Frost proof

Borehole sealing by the composite mortar prevents water penetration and frost damage in winter.



Special thread

Load transmission via undercut.



Immediately loadable

Immediately loadable without observing the curing time for the composite mortar.

Approval



- ✓ General type approval / General technical approval Z-21.1-1799.

Base Materials

- ✓ Application in cracked and non-cracked concrete of strength classes from C20/25 to C50/60.







Scan the QR code and go directly to the product page

For example, to view the approvals in detail you only need one click. Feel free to try it out!

11 TOGE TSM B

HEADSHAPES AND MATERIALS

	Steel zinc-plated	Steel, anti-corrosion-coated	Stainless steel A4
 <p>TSM B 14 M16 x 35 SW 12</p>		✓*	
 <p>TSM B 16 M18 x 45 SW13</p>		✓*	
 <p>Injection mortar and accessories</p>			
			
			

* with high quality coating
TOGE KORR

Application examples

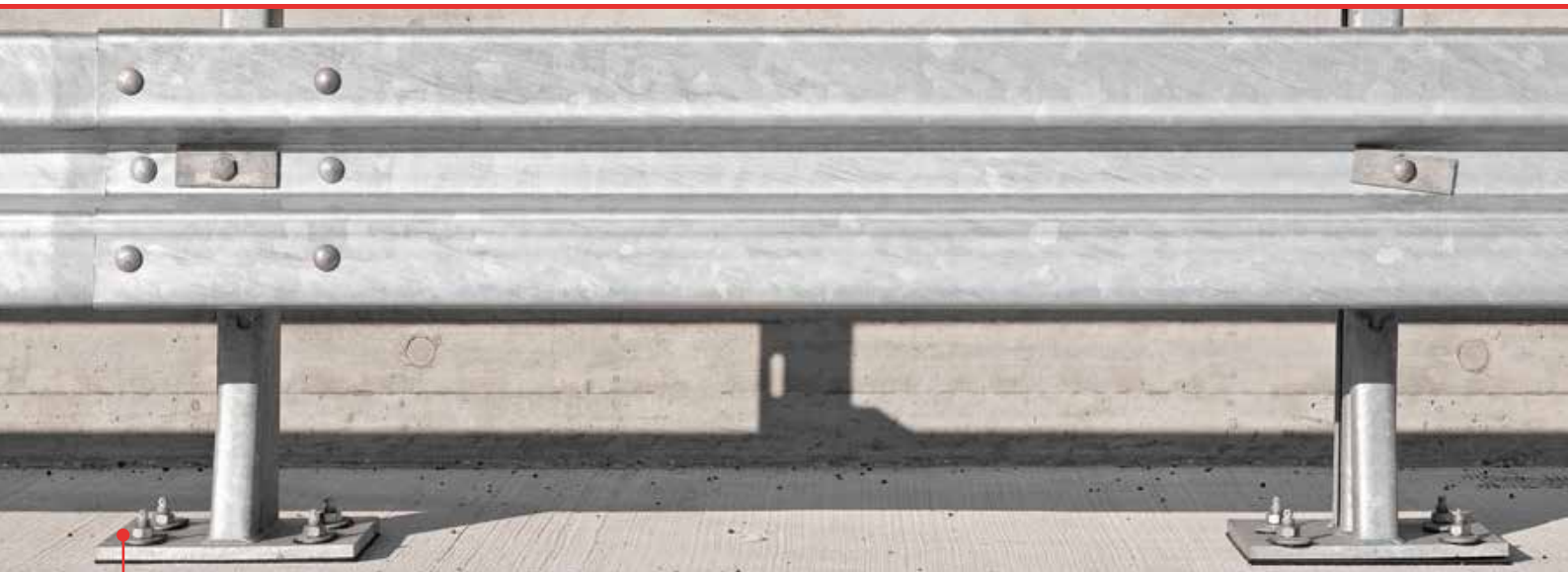

Fastening of crash barrier systems

11 TOGE TSM B

STEEL – ANTI-CORROSION COATED, TOGE KORR

TSM B14 M16 x 35 SW 12

TSM B16 M18 x 45 SW 13

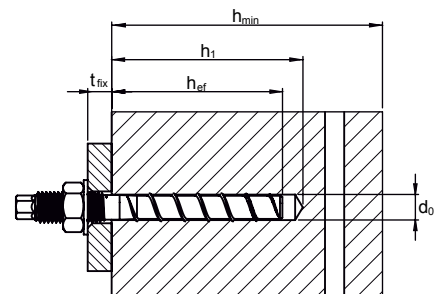

Item nr.	Designation	Bore Ø	Depth of drill hole h_0	Embedment depth of anchor h_{nom}	Max. thickness of fixture t_{fix}	Packing Unit
202 141 650	TSM B 14x165 M16x35 SW12	14 mm	≥ 100 mm	100 - 125 mm	35 mm	25
202 161 900	TSM B 16x190 M18x45 SW13	16 mm	≥ 100 mm	100 - 160 mm	60 mm	25
202 162 200	TSM B 16x220 M18x45 SW13	16 mm	≥ 100 mm	100 - 160 mm	90 mm	25
202 016 501	Scheibe TSM B 50x18x4, feuerverzinkt					100
202 014 161	Mutter M16, feuerverzinkt					50
202 016 181	Mutter M18, feuerverzinkt					50

COMPOSITE MORTAR CF-T 300V

Chemical special mortar

Vinylester styrolfree, suitable for concrete screws



Item nr.	Designation	Packing Unit
222 222 003	Cartridge CF-T 300 V	1
222 223 001	Mixing nozzle for CF-T 300 V	1
222 222 004	Squeezing pistol for CF-T 300 V	1

11 TOGE TSM B

COMPOSITE MORTAR CF-T 300V

Processing instructions
composite mortar

Temp. in ground	Processing time	Min. curing time in dry borehole	Min. curing time in wet borehole
≥ -5°C	60 min	360 min	720 min
≥ 0°C	60 min	180 min	360 min
≥ 5°C	60 min	120 min	240 min
≥ 10°C	45 min	80 min	160 min
≥ 20°C	15 min	45 min	90 min
≥ 30°C	5 min	25 min	50 min
≥ 35°C	4 min	20 min	40 min

Strokes & cartridge coverage
composite mortar

Depth of drill hole [mm]	Strokes / TSM screws Ø		Drills per cartridge / TSM screws Ø	
	14	16	14	16
80 - 90				
90 - 100				
100 - 110	1,3	1,4	28	25
110 - 120	1,4	1,6	26	23
120 - 130	1,5	1,7	24	21
130 - 140		1,8		20
150 - 160		2,0		18

11 TOGE TSM B

TECHNICAL CHARACTERISTICS

Single fastening without fire exposure, TSM B according Z-21.1-1799

Screw size TSM B			TSM B 14			TSM B 16		
Nominal embedment depth	h_{ef}	[mm]	$h_{ef,1}$	$h_{ef,2}$	$h_{ef,3}$	$h_{ef,1}$	$h_{ef,2}$	$h_{ef,3}$
			100	110	125	100	130	160
Nominal diameter of drill bit	d_0	[mm]	12			14		
Depth of drill hole	h_0 min	[mm]	100	110	125	100	130	160
Effective anchorage depth	h_{ef}	[mm]	100	110	125	100	130	160
Diameter of clearance hole in the fixture	d_f max	[mm]	18			20		
Diameter of the brush	d_b max	[mm]	15			18		
Approved tension load in cracked concrete ^{1) 2)}	N_{zul}	[kN]	16,4	19,0	22,9	18,9	24,3	33,2
Approved shear load in cracked concrete ^{1) 2)}	V_{zul}	[kN]	16,4	19,0	22,9	18,9	24,3	33,2
Approved tension load in non-cracked concrete ^{1) 2)}	N_{zul}	[kN]	23,4	27,0	32,1	27,0	34,7	39,2
Approved shear load in non-cracked concrete ^{1) 2)}	V_{zul}	[kN]	23,4	27,0	32,7	27,0	34,7	47,4
Permissible bending moment	M_{zul}	[kN]	114,3			141,1		
Minimum edge distance	c_{min}	[mm]	60			70		
Minimum spacing	s_{min}	[mm]	60			70		
Minimum Basements thickness	h_{min}	[mm]	170	180	195	170	200	230
Installation torque (with metric connection thread)	T_{inst}	[Nm]	80			100		
Maximum torque (with impact screw driver)		[Nm]	650			650		

¹⁾ For the determination of the allowable load, the partial safety factor from the approval $\gamma_M = 1.5$ was taken into account for material resistance and a partial safety factor $\gamma_F = 1.4$ for load actions.

²⁾ These values apply without influence of the spacing and edge distances.

11 TOGE TSM B

TECHNICAL CHARACTERISTICS

Single fastening under fire exposure TSM B according Z-21.1-1799

Screw size TSM B		TSM B 14			TSM B 16			
Embedment depth	h_{ef} [mm]	$h_{ef,1}$	$h_{ef,2}$	$h_{ef,3}$	$h_{ef,1}$	$h_{ef,2}$	$h_{ef,3}$	
		100	110	125	100	130	160	
Approved load under tensile and shear use ($F_{zul} = N_{zul,fi} = V_{zul,fi}$)								
Fire resistance class								
R30	Approved load	$F_{zul, fi30}$ [kN]	9,8		13,9			
R60		$F_{zul, fi60}$ [kN]	8,1		11,0			
R90		$F_{zul, fi90}$ [kN]	5,9		8,0			
R120		$F_{zul, fi120}$ [kN]	4,8		6,5			
R30		$M_{zul, fi30}$ [kN]	18,8		30,9			
R60		$M_{zul, fi60}$ [kN]	15,6		24,4			
R90		$M_{zul, fi90}$ [kN]	11,3		17,8			
R120		$M_{zul, fi120}$ [kN]	9,2		14,4			
Edge distance								
R30 bis R120		$C_{cr,fi}$ [mm]	$2 \times h_{ef}$					
The edge distance must be at least 300 mm, if the fire load attacks from more than one side.								
Spacing								
R30 bis R120	$S_{cr,fi}$ [mm]	$4 \times h_{ef}$						
Concrete pry-out failure								
R30 bis R120	k [-]	2,0						
For wet concrete, increase the anchorage depth by at least 30 mm.								

¹⁾ For the determination of the allowable load, the partial safety factor from the approval $\gamma_M = 1.0$ was taken into account for material resistance and a partial safety factor $\gamma_F = 1.0$ for load actions.

11 TOGE TSM B

INSTALLATION INSTRUCTIONS

Installation instructions

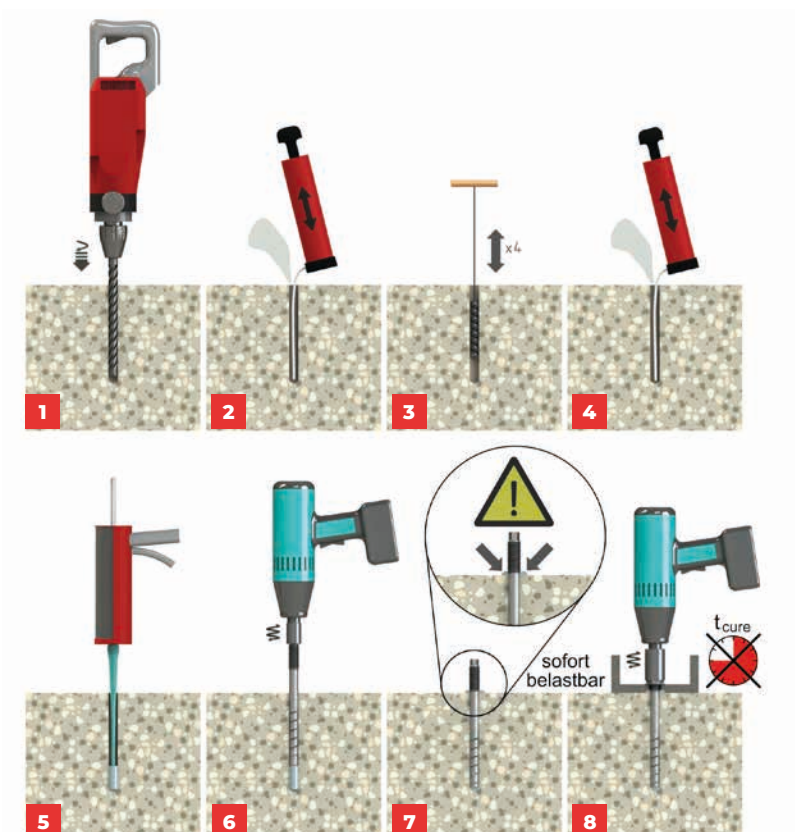

- 1 Create borehole.
- 2 Clean the borehole thoroughly.
- 3 Brush the borehole 4x.
- 4 Thoroughly clean the borehole again.
- 5 Discard three full strokes of composite mortar – then inject composite mortar.
- 6 Screw in concrete screw.
- 7 After reaching the embedment depth, the composite mortar must emerge at the concrete surface.
- 8 The attachment can be installed immediately – there is no need to observe the curing time of the composite mortar.

**THE
FASTENING
EXPERTS**



SECURE FASTENING SINCE 1964



TOGE Dübel GmbH & Co. KG

Illesheimer Straße 10
90431 Nuremberg

Phone: +49 (0)911 65 96 8-0
Fax: +49 (0)911 65 96 8-50
E-mail: sales@toge.de

[toge.de/en/](https://www.toge.de/en/)